



# Ligh Commercial

## Technical & Service Manual

EUROPE R32 T1 SERIES  
DC INVERTER



Technology Leads Intelligent Life

Version 17

2024.08.13

## Contents

Part1 General Information .....	3
Part2 Features.....	7
Part3 Piping System.....	19
Part4 Dimension .....	20
Part5 Electrical Principal Diagram.....	30
Part6 Capacity Amendment.....	36
Part7 Static pressure curve .....	40
Part8 Sound level .....	43
Part9 Controller .....	64
Part10 PCB Instruction.....	82
Part11 Protection.....	92
Part12 Electric Characteristic .....	94
Part13 Trouble Shooting.....	95

# Part1 General Information

## 1. Nomenclature

### Indoor Unit

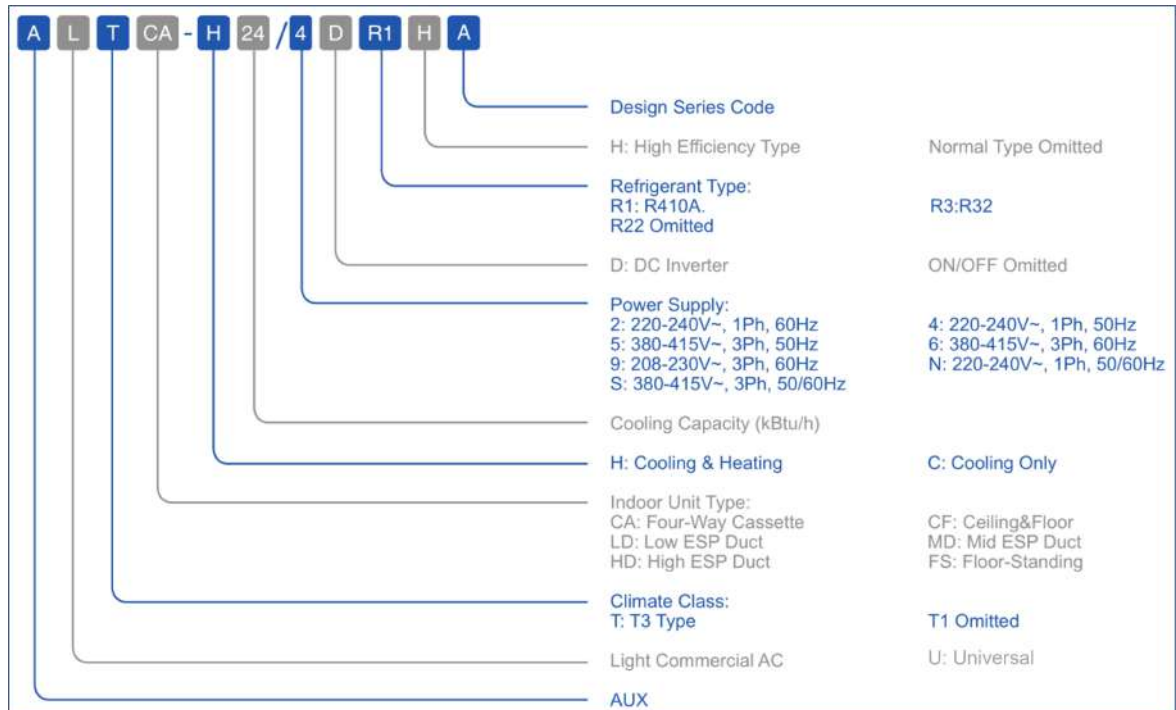



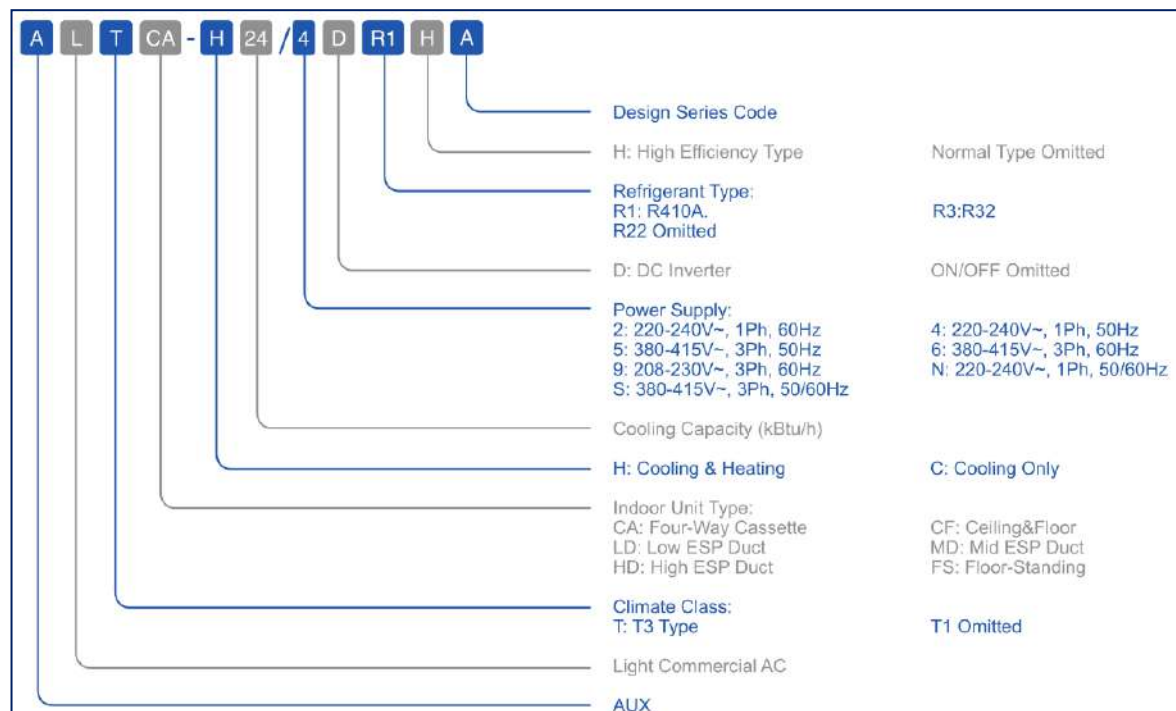

### Outdoor Unit:



## 2. Unit appearance

### 2.1 Cassette (Y type)-LNS communication



Type	Picture	Capacity Range / Model		Dimension	Launch time
Compact cassette Y series		12 K	AUCA-H12/4DR3HYAB	570×570×260	2022.05
		18 K	AUCA-H18/4DR3HYAB		2022.06
Round-flowy cassette Y series		24 K	AUCA-H24/4DR3HYAB	840×840×246	2022.05
		36 K	AUCA-H36/NDR3HYCB	840×840×288	2023.09
		42 K	AUCA-H42/NDR3HYCB		
		48 K	AUCA-H48/SDR3HYCB		
		60 K	AUCA-H60/SDR3HYCB		

Capacity	Standard Panel	Optional Panel
12~60 K		

### 2.2 Ceiling Floor (F type) -LNS communication

Type	Picture	Capacity Range / Mode		Dimension	Launch Time
Ceiling Floor (F Type)		18 K	AUCF-H18/4DR3HFA	1000×690×235	2022.05
		24 K	AUCF-H24/4DR3HFA	1280×690×235	2022.05
		36 K	AUCF-H36/NDR3HFC	1600×690×235	2023.08
		42 K	AUCF-H42/NDR3HFC		
		48 K	AUCF-H48/SDR3HFC		
		60 K	AUCF-H60/SDR3HFC		

2.3 Duct (M type) -LNS communication

Type	Picture	Capacity Range / Mode		Dimension	Launch Time
M DUCT		12 K	AUMD-H12/NDR3HM2B	700x700x245	2023.01
		18 K	AUMD-H18/NDR3HM2B		2022.11
		24 K	AUMD-H24/NDR3HM2B	1000x700x245	2022.05
		30 K	AUMD-H30/NDR3HC		
		36 K	AUMD-H36/NDR3HC		2023.09
		42 K	AUMD-H42/NDR3HC		
		48 K	AUMD-H48/SDR3HC		2023.08
		60 K	AUMD-H60/SDR3HC		

2.4 Console-LNS communication

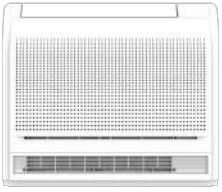
Picture	Capacity Range / Mode		Dimension	Launch Time
	12 K	AUCO-H12/4DR3HA	700×225×600	2022.10
	18 K	AUCO-H18/4DR3HA		

2.5 Outdoor Unit-LNS communication

Series	Capacity (K Btu/h)	Models	Photos	Dimension	Launch Time
Outdoor units	12	AL-H12/NDR3HB2(U)		709×536×280	2022.06
	18	AL-H18/NDR3HB2(U)		785×300×555	2022.05
	24	AL-H24/NDR3HB2(U)		900×350×700	
	30	AL-H30/NDR3HB2(U)			
	36	AL-H36/NDR3C2(U)		970×395×805	2023.09
	42	AL-H42/NDR3C2(U)			
	48	AL-H48/SDR3C2(U)		940×370×1325	2023.08
	60	AL-H660/SDR3C2(U)			

# Part2 Features

## 1. Outdoor Units

### High Efficiency

Equipped with high efficiency DC Inverter compressor, adjustable fan motor and advanced 180° sine wave vector driver, the system can be higher than 6.1 in SEER and 4.0 in SCOP so as to meet the European and Australian new energy efficiency standards.

### Reliability

Stable cooling under -15°C and heating under -15°C outdoor environment temperature.

### 180°Sine Wave Control

DC inverter compressor uses 180°sine wave vector control technique, make compressor motor operate smoothly and efficiency increases significantly.

### Optimized Pipeline Design

The design ensures the sub-cooling and enhances the cooling capacity by separating the refrigerant inlet and outlet.

### Simulation Technology

Via analyzing piping stress distribution, piping amplitude and displacement in transportation and operation, the reliability has been improved greatly.

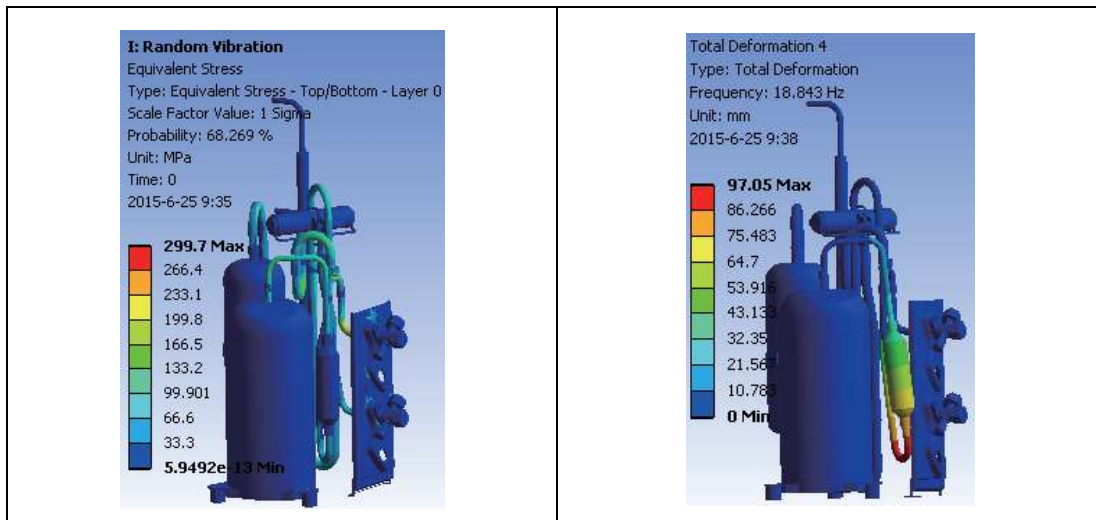

### Electrical heater (Optional)

#### Heater code: 11330029000010 220V 50W

The electrical heater is used to melt ice on the chassis, make sure good heat exchange performance for condenser, powerful heating performance in very cold condition and create comfortable environment.



### Heating only function (Optional)

Cooling & heating is standard, heating only is optional. Pls refer to Part 9.2.2 Parameter setting.

## 2. Cassette

### 2.1 Round-flow Cassette

Four-way cassette type A/C is installed under the ceiling, compared with Floor & Standing type A/C, it has following advantages: Ceiling installation combining with the decoration, makes the room more elegant; Flexible installation in anywhere in the ceiling and 4-direction blowing, makes you feel more comfortable.

### Built-in Drain Pump

The built-in drain pump can lift condensing water up to 1200mm high from the drainage pan.

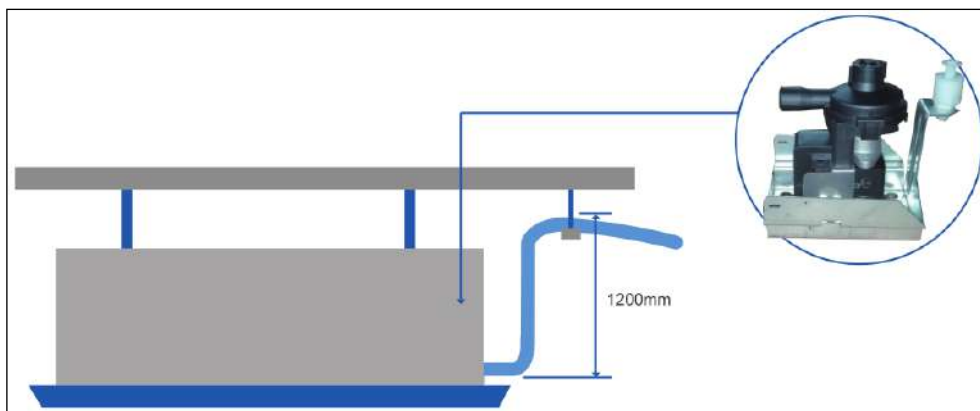

### Fresh Air Intake

Fresh air makes indoor air healthy and comfortable.

### Optimized Electric Box

Better fire-proof and easy to maintenance.

## 2.2 Compact Y Cassette

### 2.2.1. Large air flow

Optimized structure of air guide ring, Insertion depth design of guide ring through simulation technology, Ensure the large air flow, improve cooling & heating comfort

Compact cassette	New Y model	Old E model
Photos		
Simulation of air flow		
Indoor Air Flow (H/M/L) m <sup>3</sup> /h	<b>760/650/580</b>	700/600/530

※ Above Air flow is rated data of R32 DC inverter series

### 2.2.2. Low Operation Noise

Optimize structure design of air guide ring, chassis and wind wheel to effectively reduce air volume noise and abnormal noise. The air volume is larger but the noise is lower

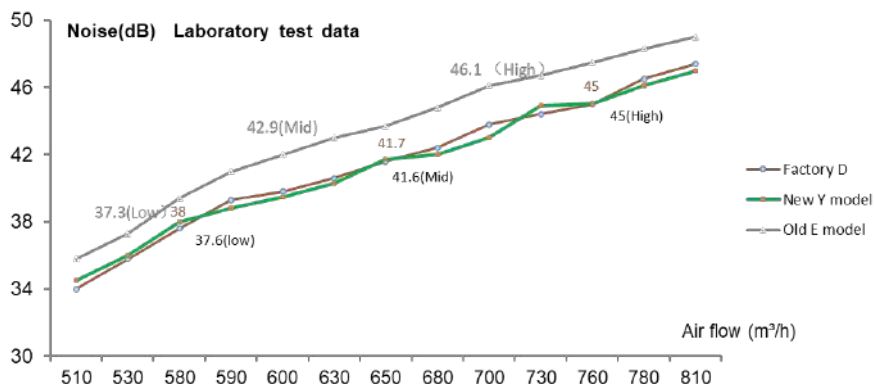

### 3. Ceiling Floor

#### 3.1 Ceiling Floor F Type

##### 3.1.1 Comfortable

##### Anti-condensation

Unique air outlet insulation and wind guide bar arc design (Coanda effect), no condensation time from 4h to 6h, higher than the industry level.



##### Strong air supply

Super air supply distance, the air supply volume is higher than the industry level to meet the circulation air supply of the whole room.

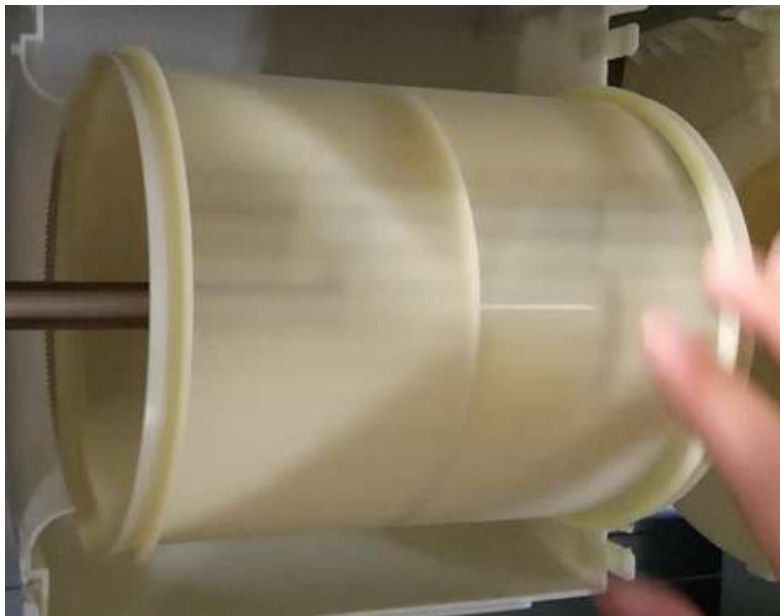

**Bring fresh air**

Fresh air inlet design can bring fresh air into the room to ensure fresh air in the room.

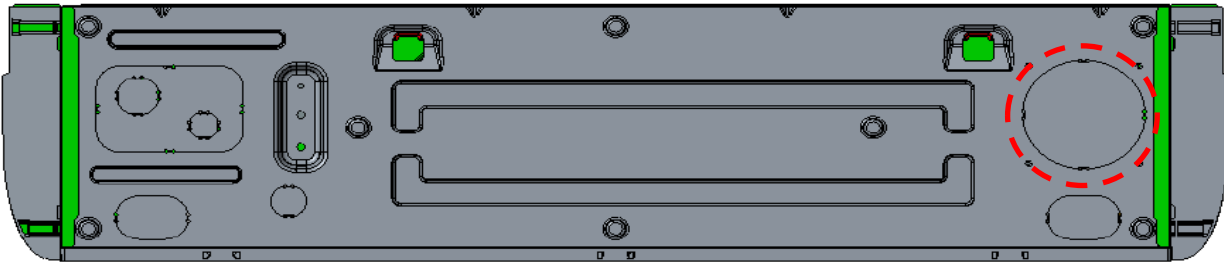

**Degradation of formaldehyde**

The filter screen can be equipped with a formaldehyde removal module to ensure fresh air in the room.



**Low noise**

High quality wind wheel/turbine selection, using simulation design, the lowest noise than the industry level.

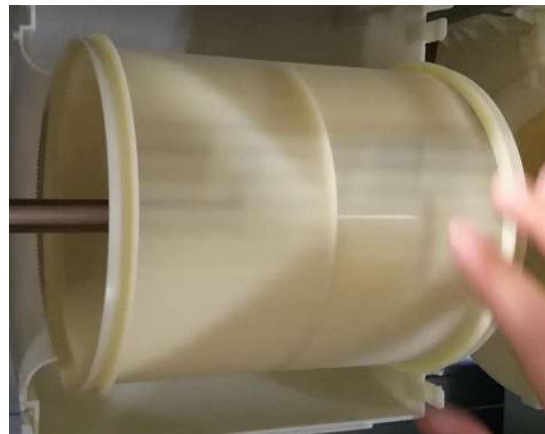

### 3.1.2 Convenient and efficient

#### Easy unpick and wash

Return air grille, filter screen cover is removed and cleaned.

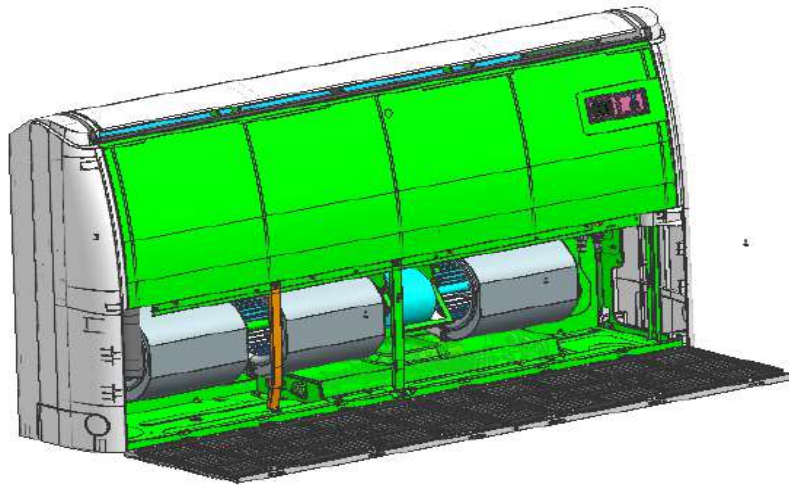

#### Easy Installation

Can be hoisted, can be mounted; Removable load-bearing rod can be installed flexibly, and the rod can be fine-tuned up and down to adjust the horizontal Angle of machine hoisting

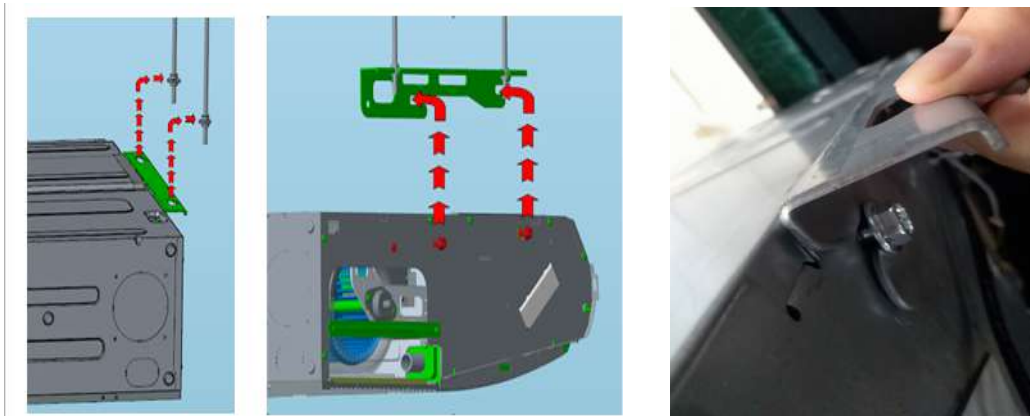

#### Easy drainage

The left and right water outlet design of the receiving tray is flexible to adapt to the installation site



**Easy maintenance**

Easy to repair, screw two screws, do not need to remove, left and right end cover 1 screw quickly remove, step motor 2 screws have been repaired, the bottom space is easy to repair

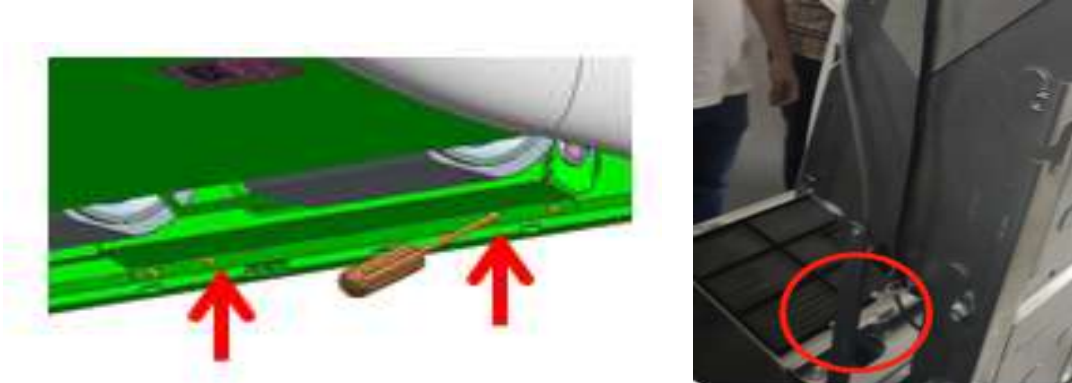

**3.1.3 Stable and Reliable**

**The face plate is elegant, the display board is beautiful**

Matte white panel design, high-end elegant

Lamp board design beautiful, and good sealing, moisture proof, long reliable life



**Strong catchment**

Excellent water collection structure design, whether in lifting or upright installation can well collect condensed water to the water tray, avoid leakage

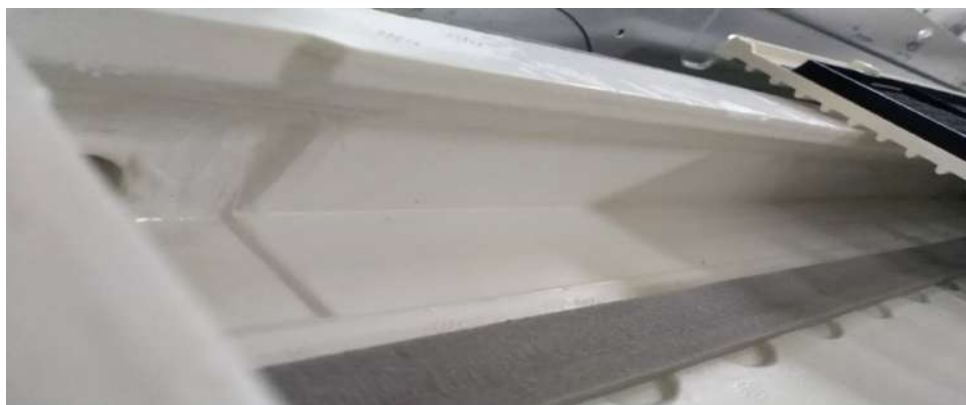

**Safe and reliable**

Strong and weak electric connection terminals are separated to ensure safe and reliable use of electricity



### 4. Medium duct

#### Constant Air Flow Volume

Under different ESP, the product supply Constant air flow volume for comfort.

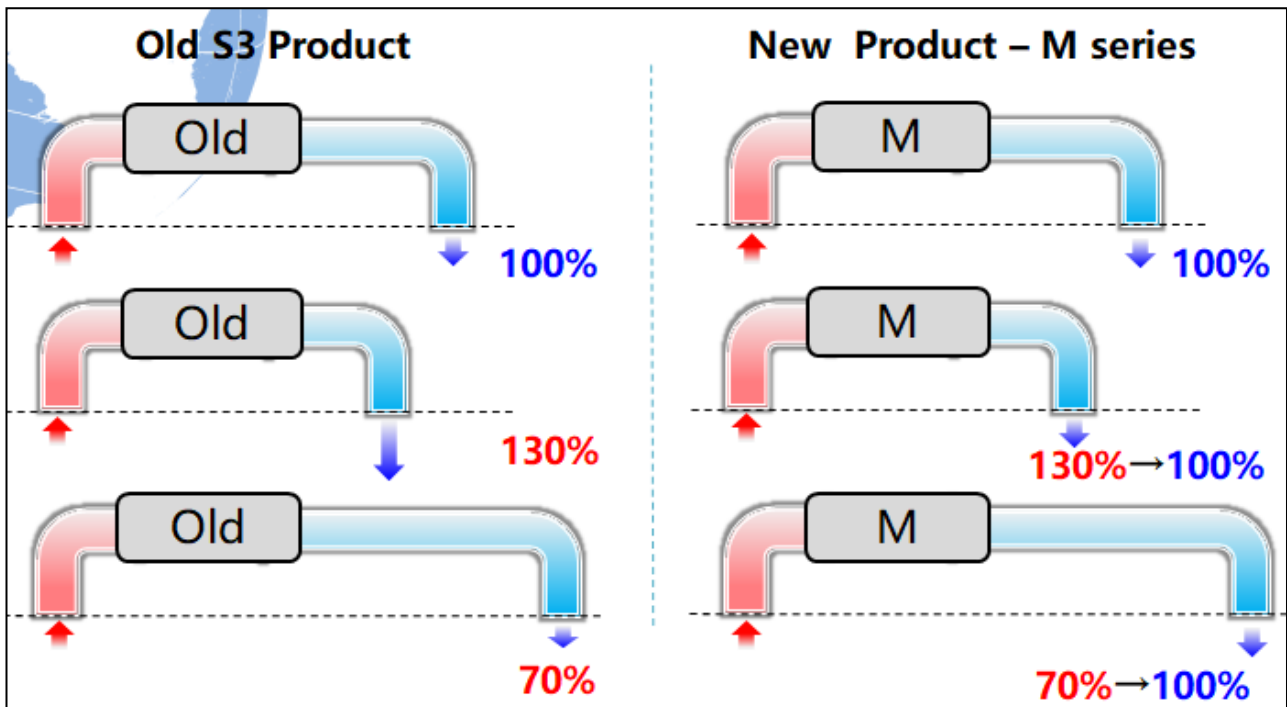

#### Two-way drain pan

**Daikin Drain Pan**  
 plastic suction, 1 way



**Old product Drain Pan**  
 printed steel, 1 way



**New Drain Pan**  
 plastic suction, 2 way,  
 Convenient for installation

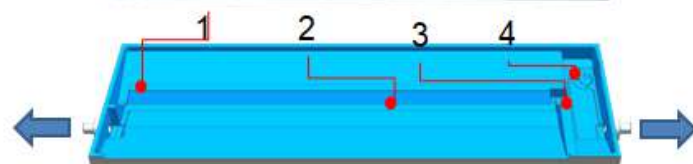

4-step Drain Pan (same as Daikin)  
 Less storage water

### Independently designed bottom flange

Independently designed bottom flange, the air duct will not be damaged in maintenance.  
Easy for maintenance.

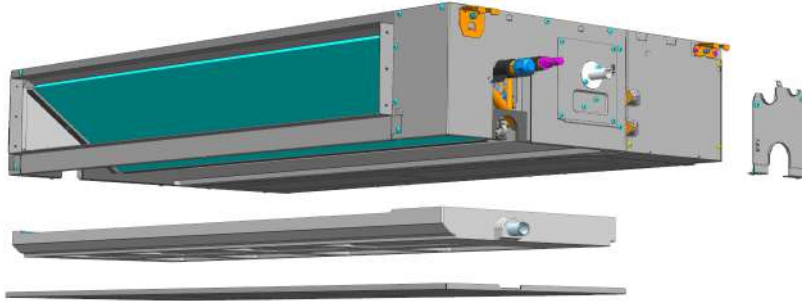

### Easy disassembly filter

0 Screws, Easy disassembly, convenient for washing, W type highly efficient filter



Optimized Centrifugal Fan

Old Fan

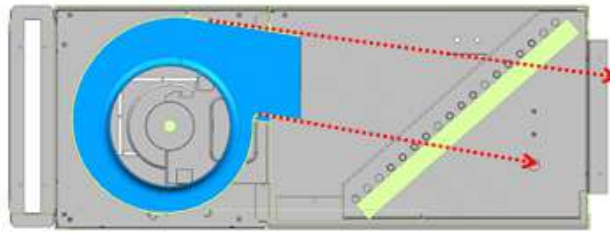

New Fan

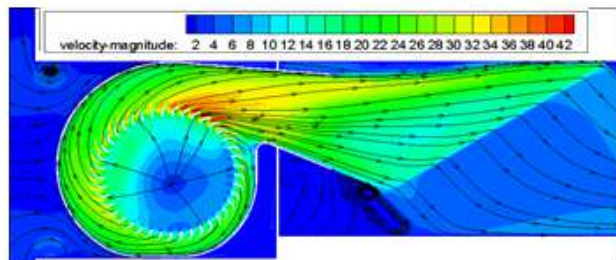
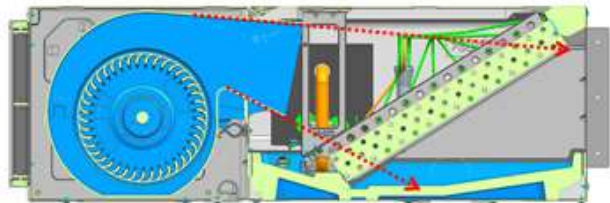

Removable Control Box

Daikin product



Non-removable

Old-S3 series

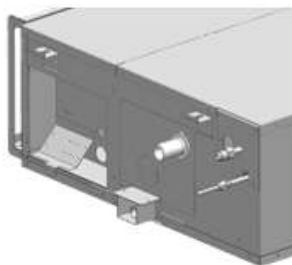

Not easy for remove

New product M series

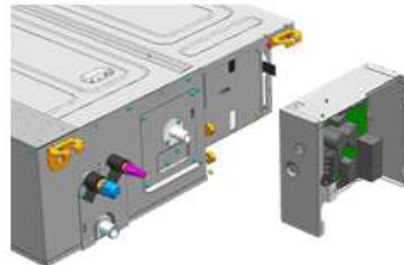

2 Screws, easy for remove  
Easy for maintenance

## **5. Console**

### **5.1 Strong heating capacity**

Full DC inverter air source heat pump heater

It can easily cope with various harsh outdoor environment in winter and create a warm and healthy home for you

### **5.2 Approximate to Floor heating**

The wind blows from the bottom, and the feet are warm; the wind blows from the top, it heats up quickly the temperature rise rate is faster than conventional floor heating. Bring comfortable heating enjoyment

### **5.3 Full DC inverter technology**

Both indoor and outdoor units adopt full DC inverter technology, which is highly efficient and energy-saving

### **5.4 Continuous heating**

Under low temperature conditions, it can be continuously heated for a long time without defrosting, no obvious temperature fluctuations, and enjoy a comfortable heating.

### **5.5 Purify first**

The console has a long-lasting air filter, making the air fresher and healthier, creating a healthy home for you.

# Part3 Piping System

The compressor inhales the low-temperature and low-pressure refrigerant vapor from the evaporator, and vapor be turned into high-temperature and high-pressure gas then enters into condenser, the high-temperature and high-pressure refrigerant gas and outdoor air make heat exchange in the condenser, the compressed vapor is then cooled by heat exchange with the outside air, so that the vapor condenses to be a high-temperature and high-pressure fluid, and then through capillary throttling to cooled, low pressure, then the liquid enters into the evaporator and two-phase of gas and liquid refrigerant in the evaporator completely evaporate, thereby cooling the indoor air; from evaporator the vapor is inhaled into compressor again, so it runs continuously cycle to cycle, cooled air is continuous supplied to the air-conditioned area though duct by fan motor.

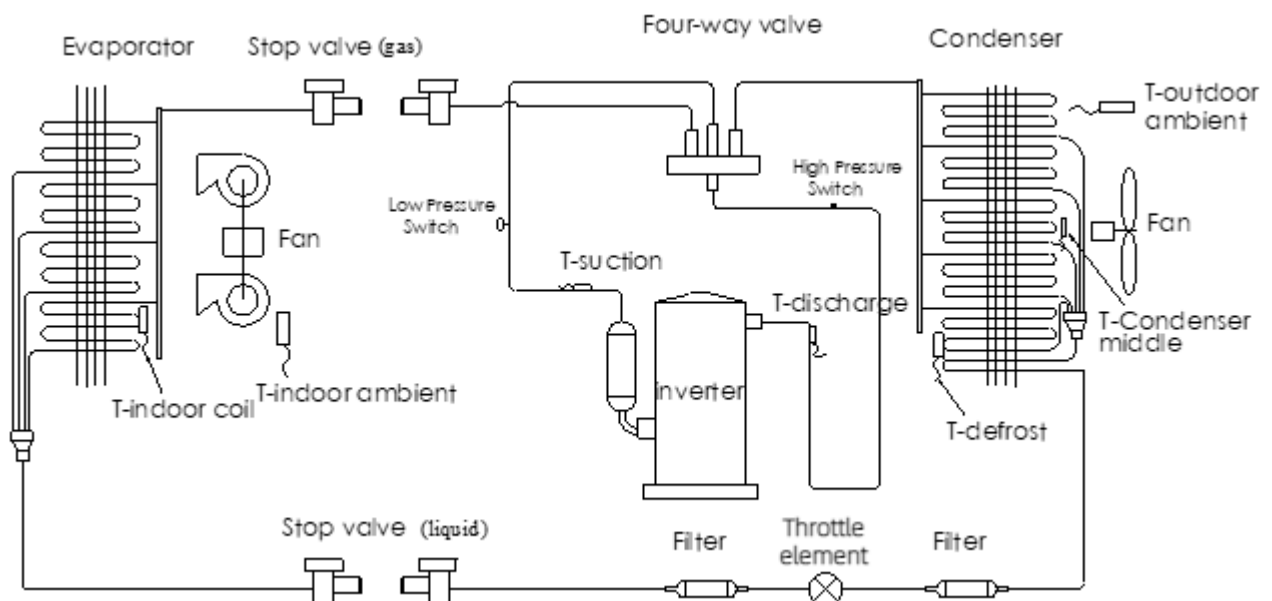

Note: The throttle elements of 12k, 18k, 24k, and 30k models is capillarie, and the rest is EEV

# Part4 Dimension

## 1. Cassette

### 1.1 Compact cassette

AUCA-H12/4DR3HYAB, AUCA-H18/4DR3HYAB

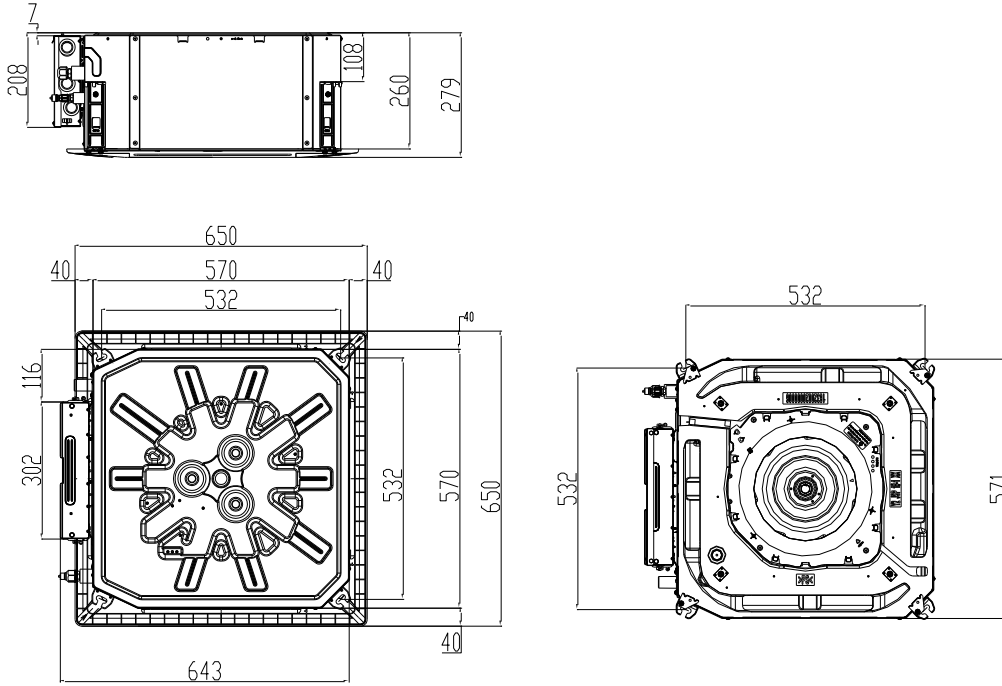

### 1.2 Cassette

**AUCA-H24/4DR3HYAB**

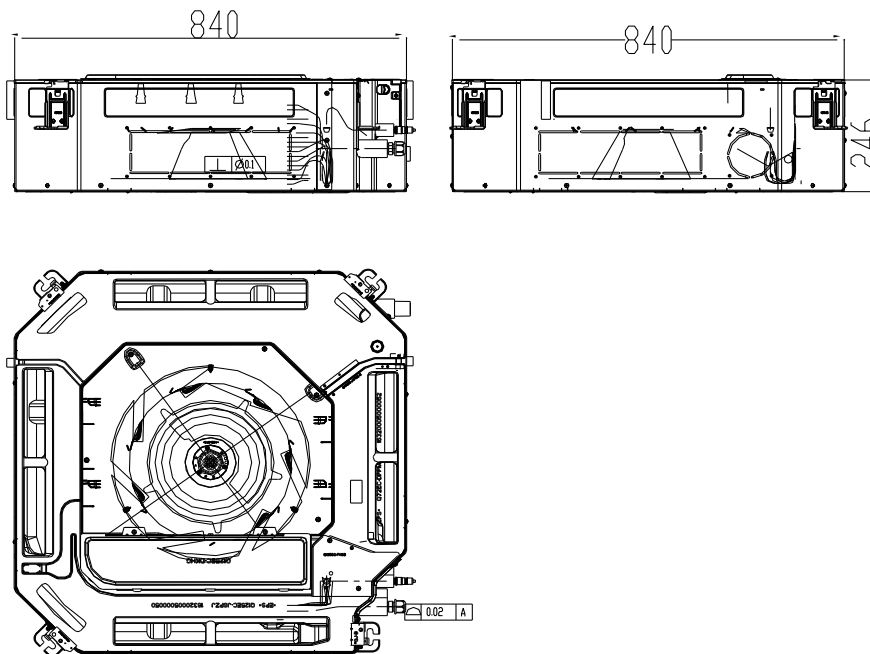

AUCA-H36/NDR3HYCB, AUCA-H42/NDR3HYCB, AUCA-H48/SDR3HYCB, AUCA-H60/SDR3HYCB

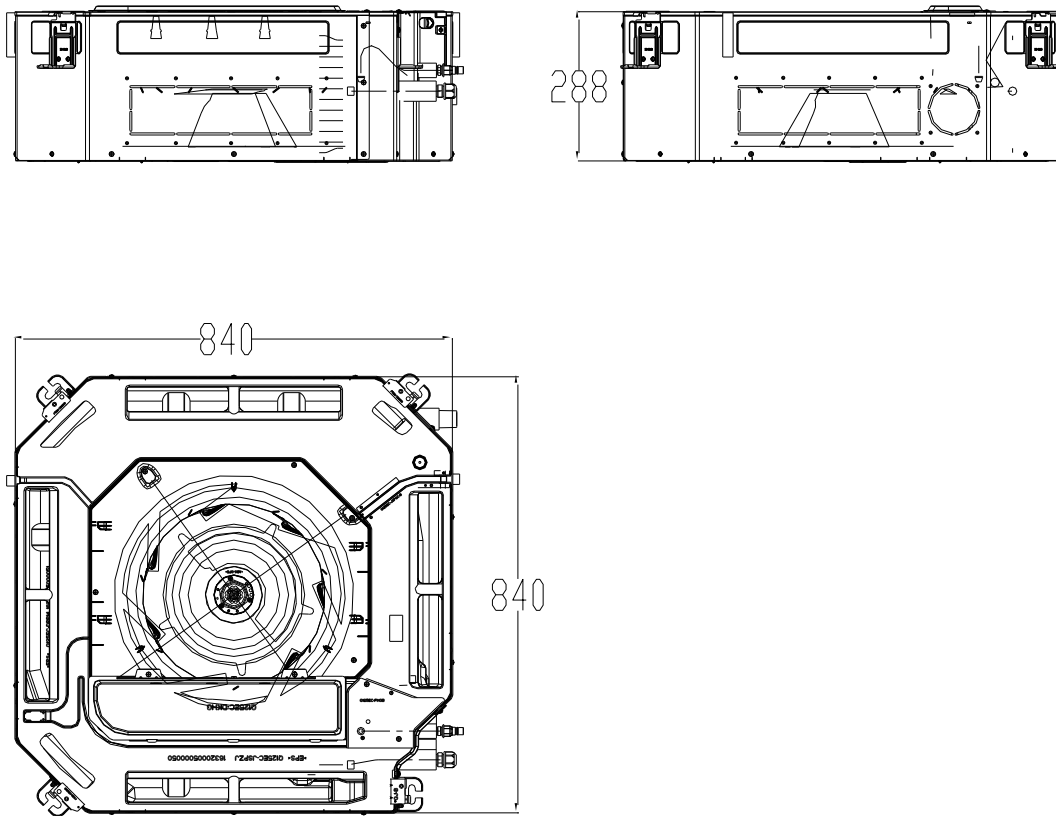

## 2. Ceiling Floor

AUCF-H18/4DR3HFA

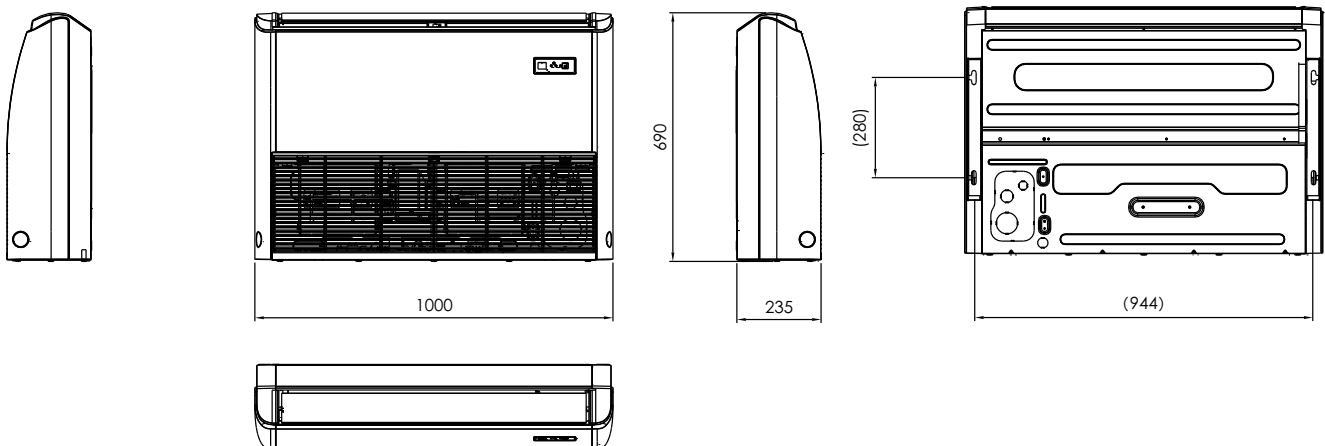

**AUCF-H24/4DR3HFA**

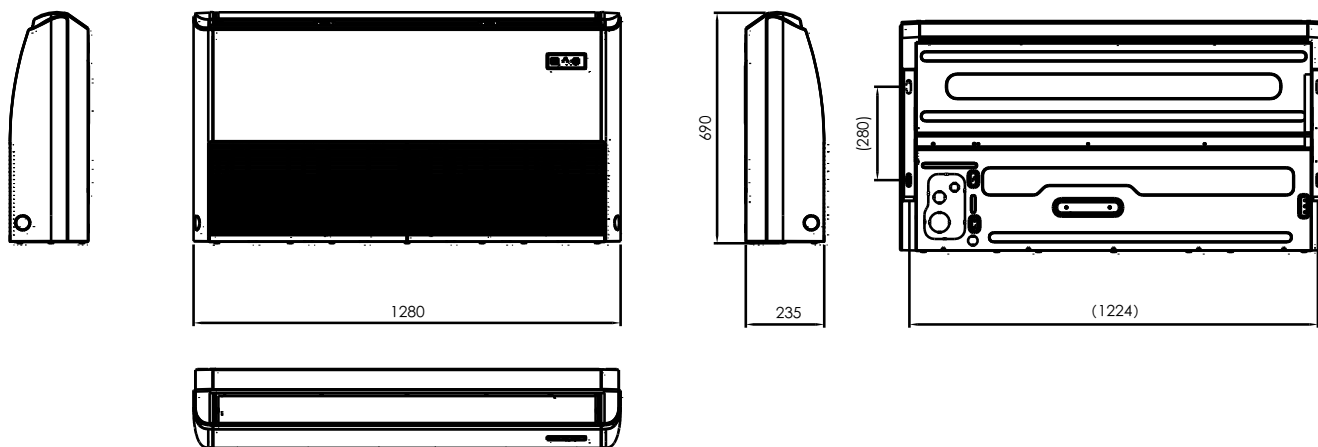

**AUCF-H36/NDR3HFC, AUCF-H42/NDR3HFC, AUCF-H48/SDR3HFC, AUCF-H60/SDR3HFC:**

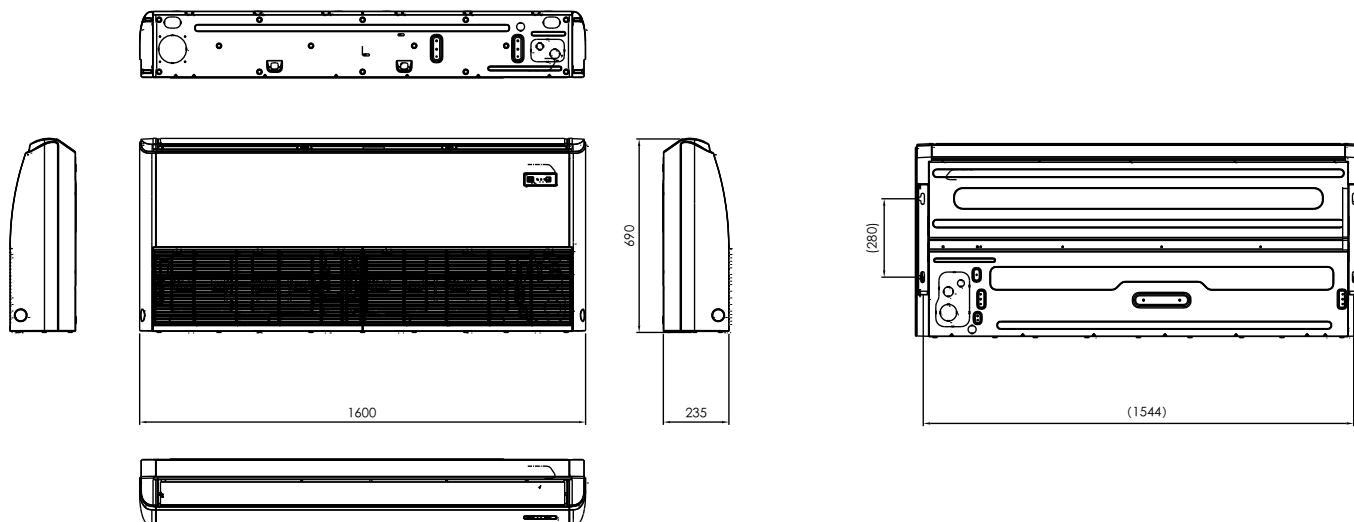

### 3. Duct

AUMD-H12/NDR3HM2B, AUMD-H18/NDR3HM2B

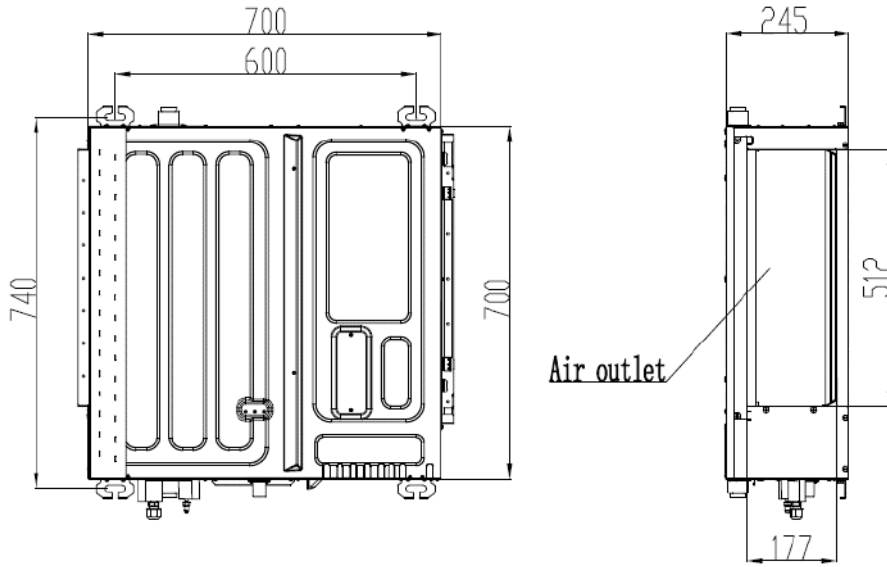

W-type filter

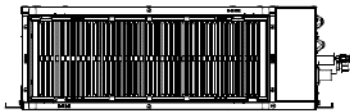

Air return (W-type filter)

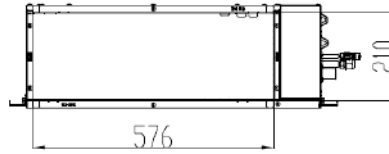

Normal filter

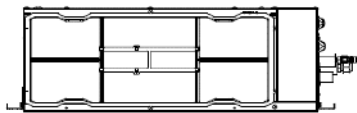

Air return (Normal filter)

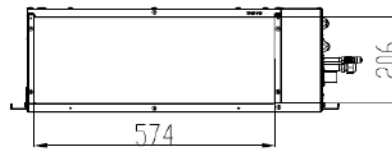

AUMD-H24/NDR3HM2B, AUMD-H30/NDR3HC

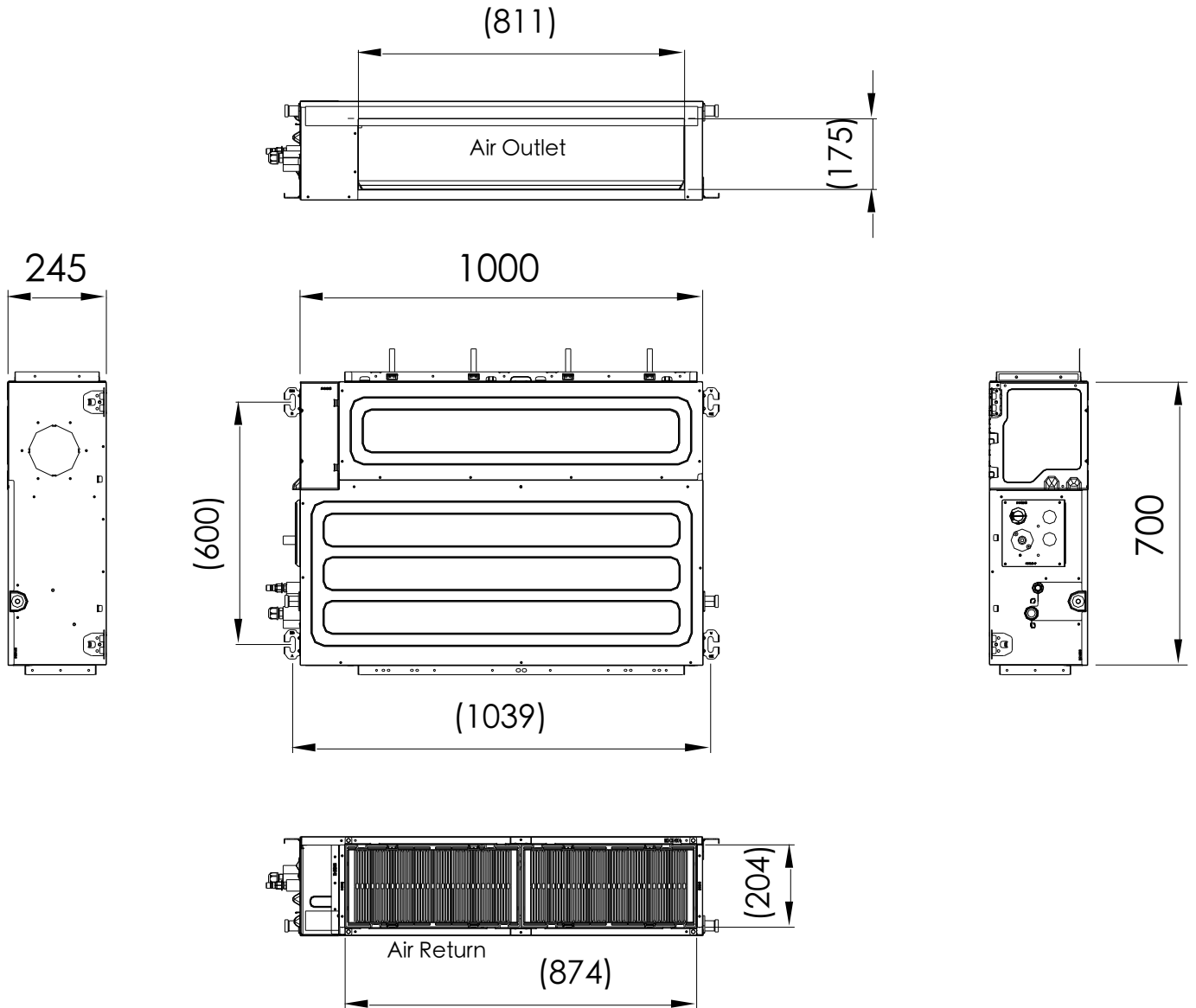

AUMD-H36/NDR3HC, AUMD-H42/NDR3HC, AUMD-H48/SDR3HC, AUMD-H60/SDR3HC

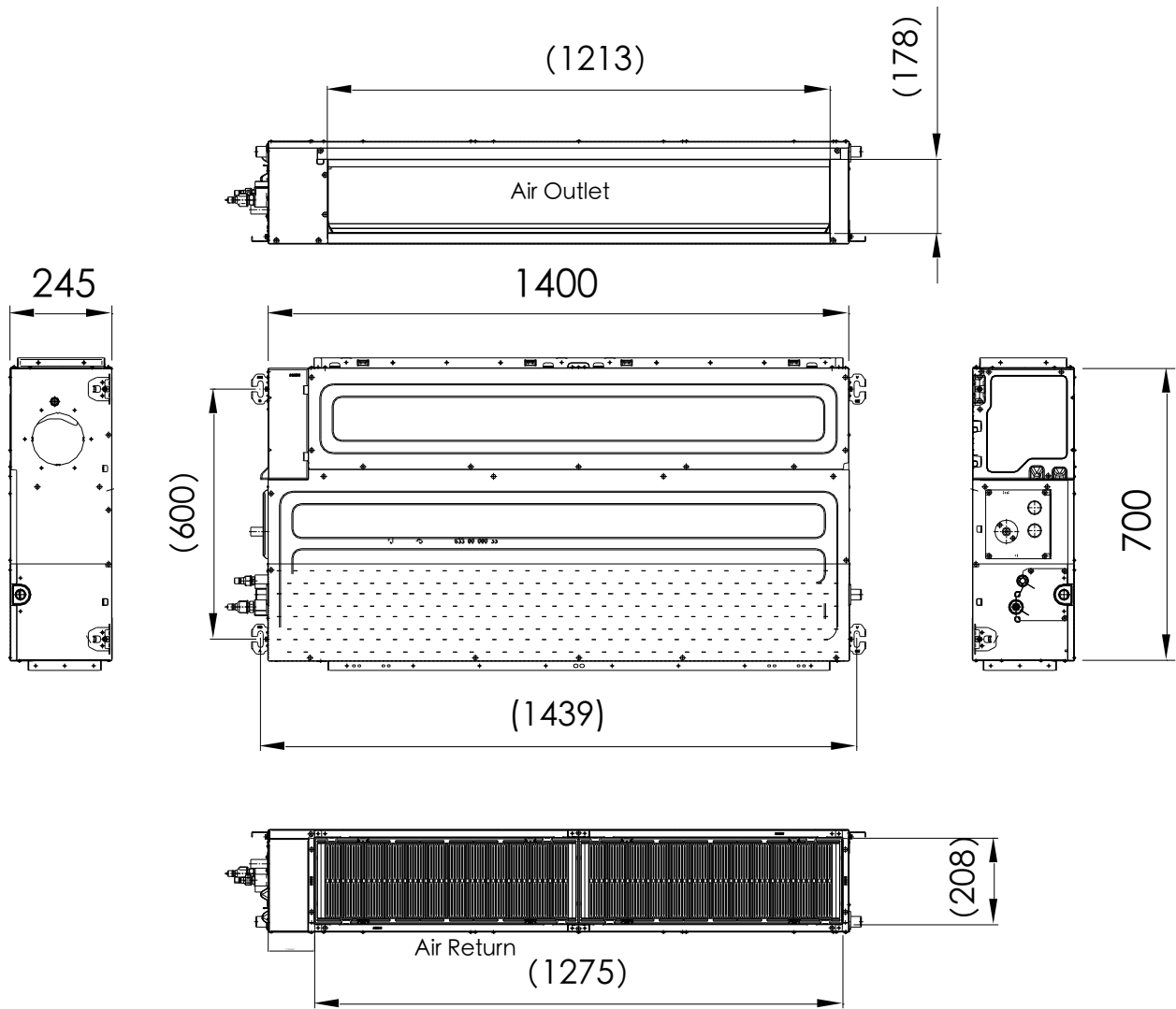

## 4. Console

AUCO-H12/4DR3HA, AUCO-H18/4DR3HA

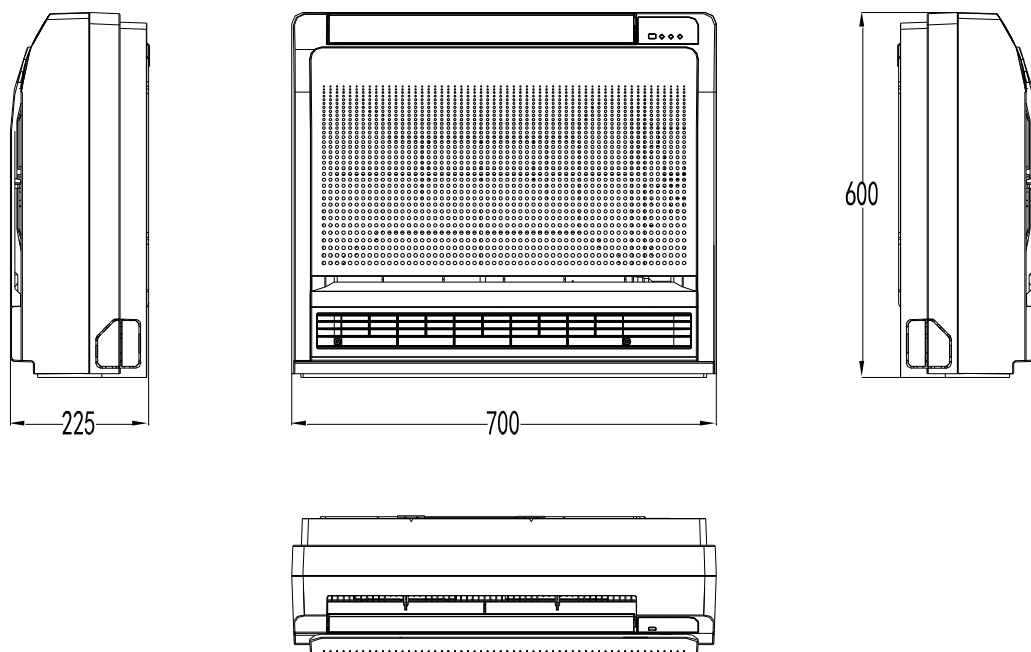

## 5. Outdoor Unit

### 5.1 AL-H12/NDR3HB2(U)

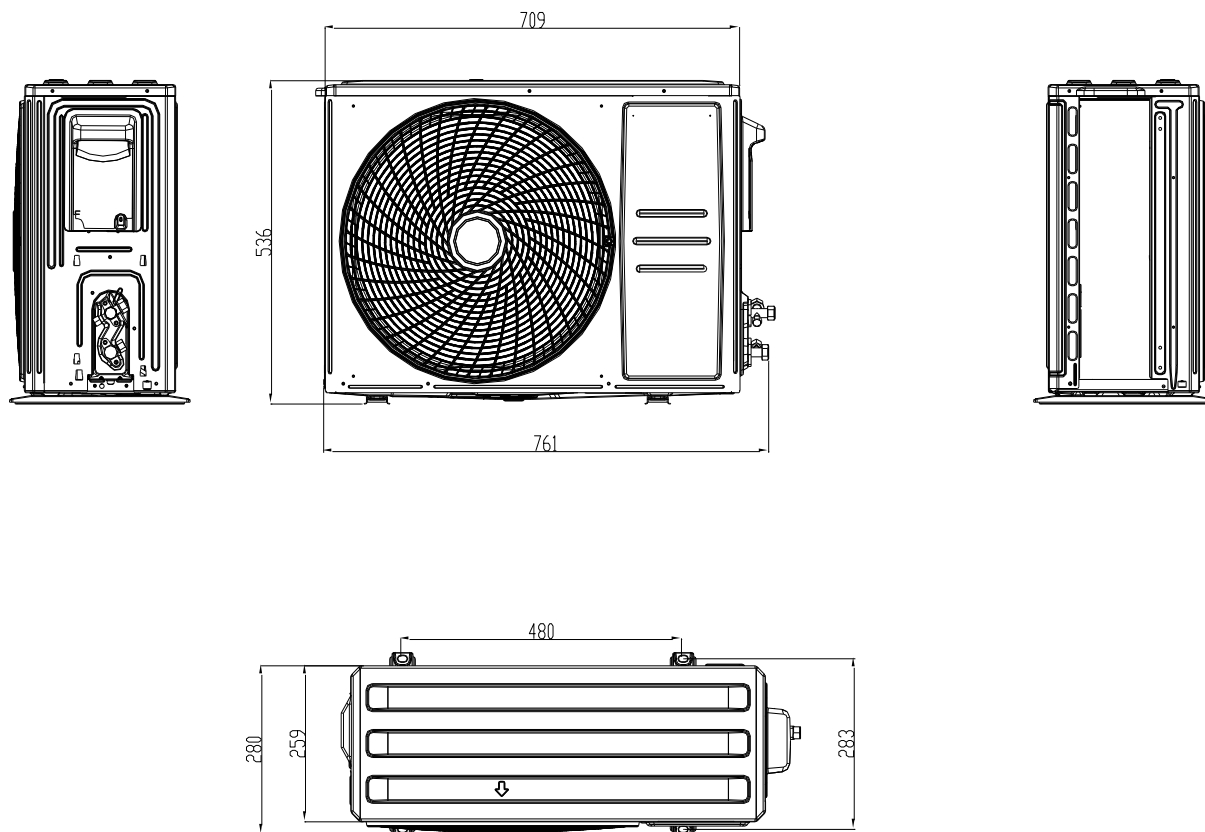

5.2 AL-H18/NDR3HB2(U)

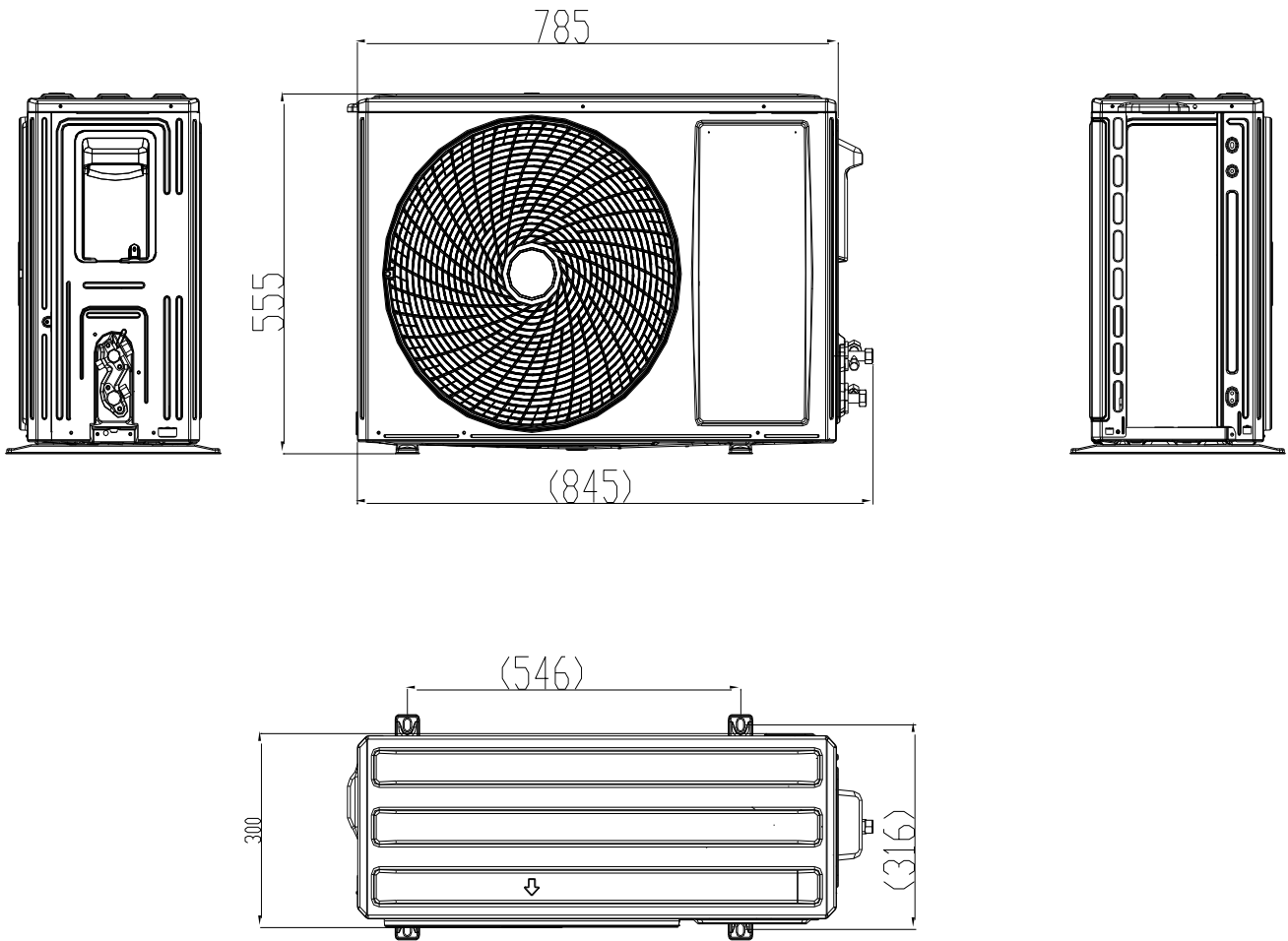

5.3 AL-H24/NDR3HB2(U), AL-H30/NDR3HB2(U)

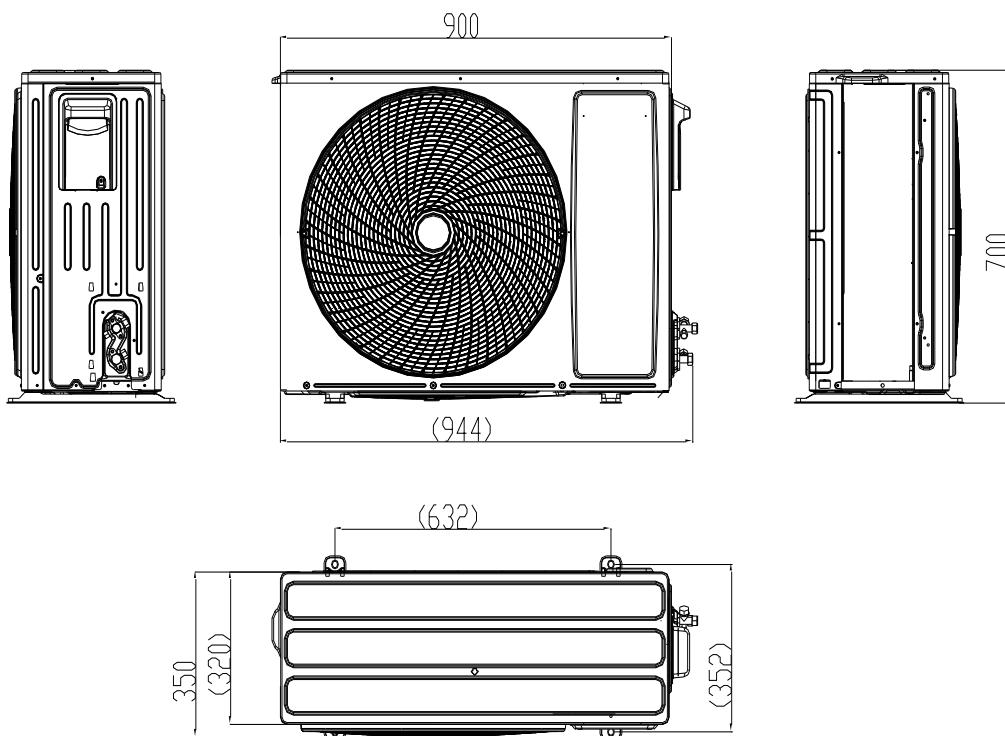

5.4 AL-H36/NDR3C2(U), AL-H42/NDR3C2(U)

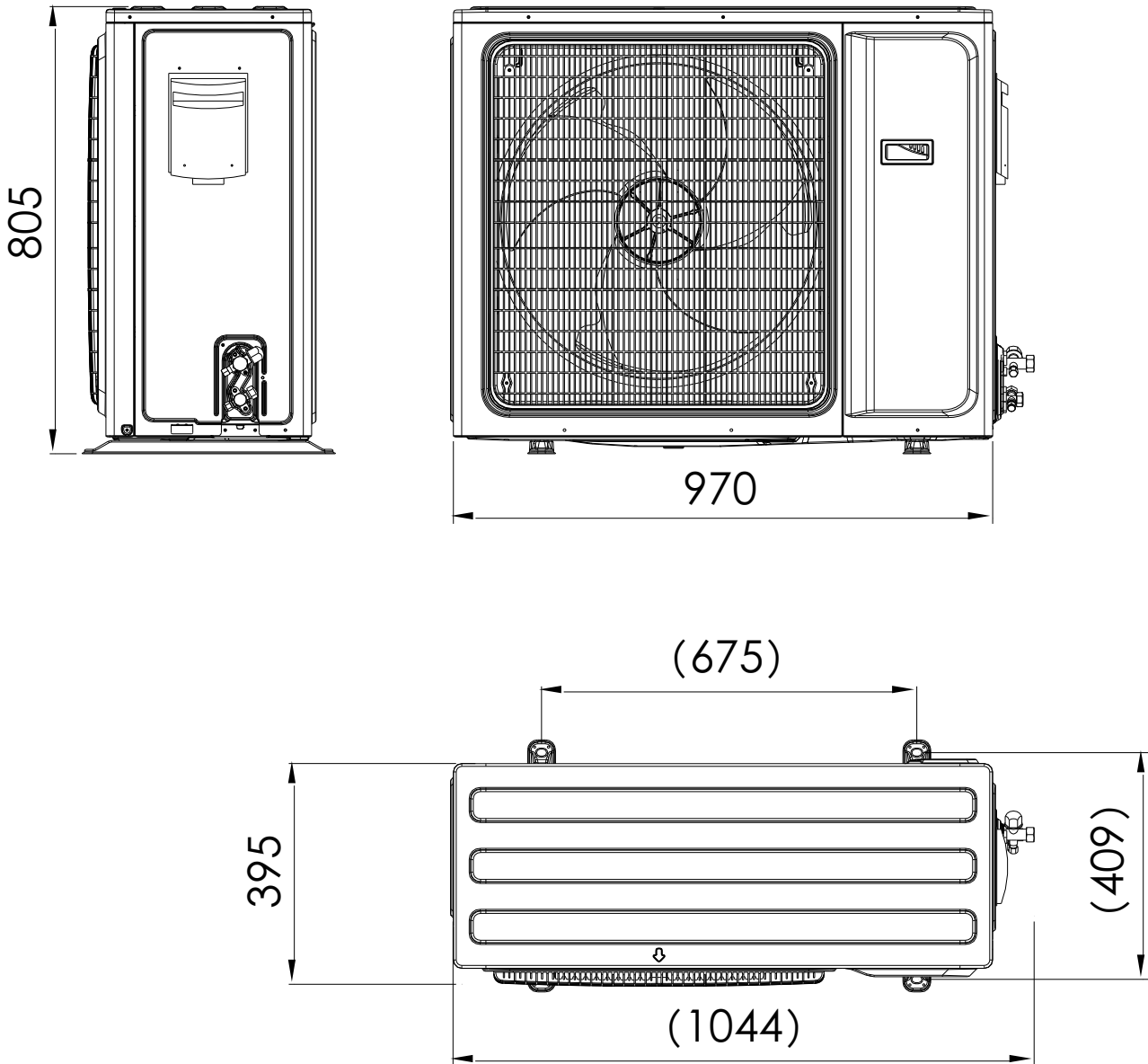

5.5 AL-H48/SDR3C2(U), AL-H60/SDR3C2(U)

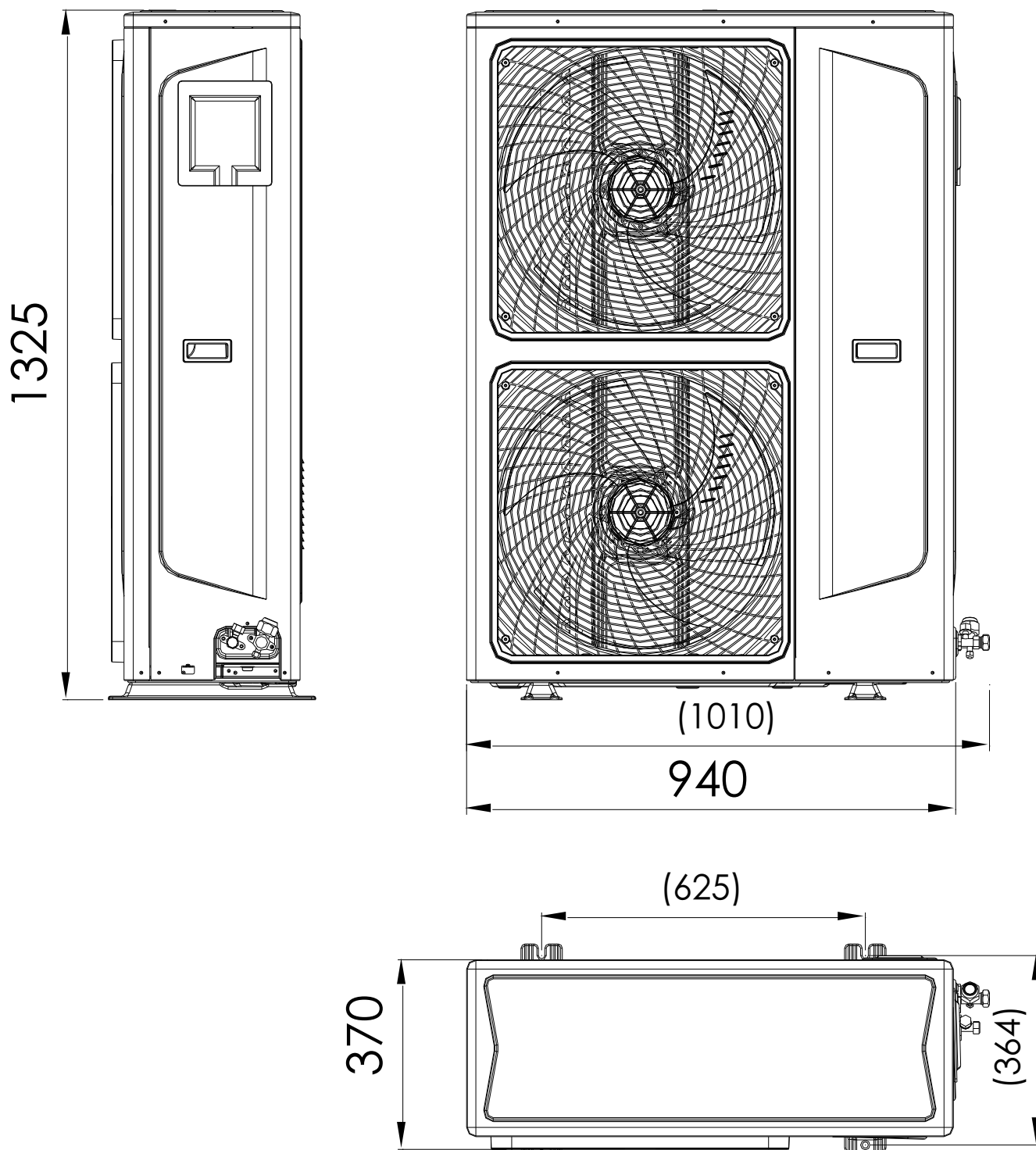

# Part5 Electrical Principal Diagram

## 1. Cassette

AUCA-H12/4DR3HYAB, AUCA-H18/4DR3HYAB, AUCA-H24/4DR3HYAB

AUCA-H36/NDR3HYCB, AUCA-H42/NDR3HYCB, AUCA-H48/SDR3HYCB, AUCA-H60/SDR3HYCB

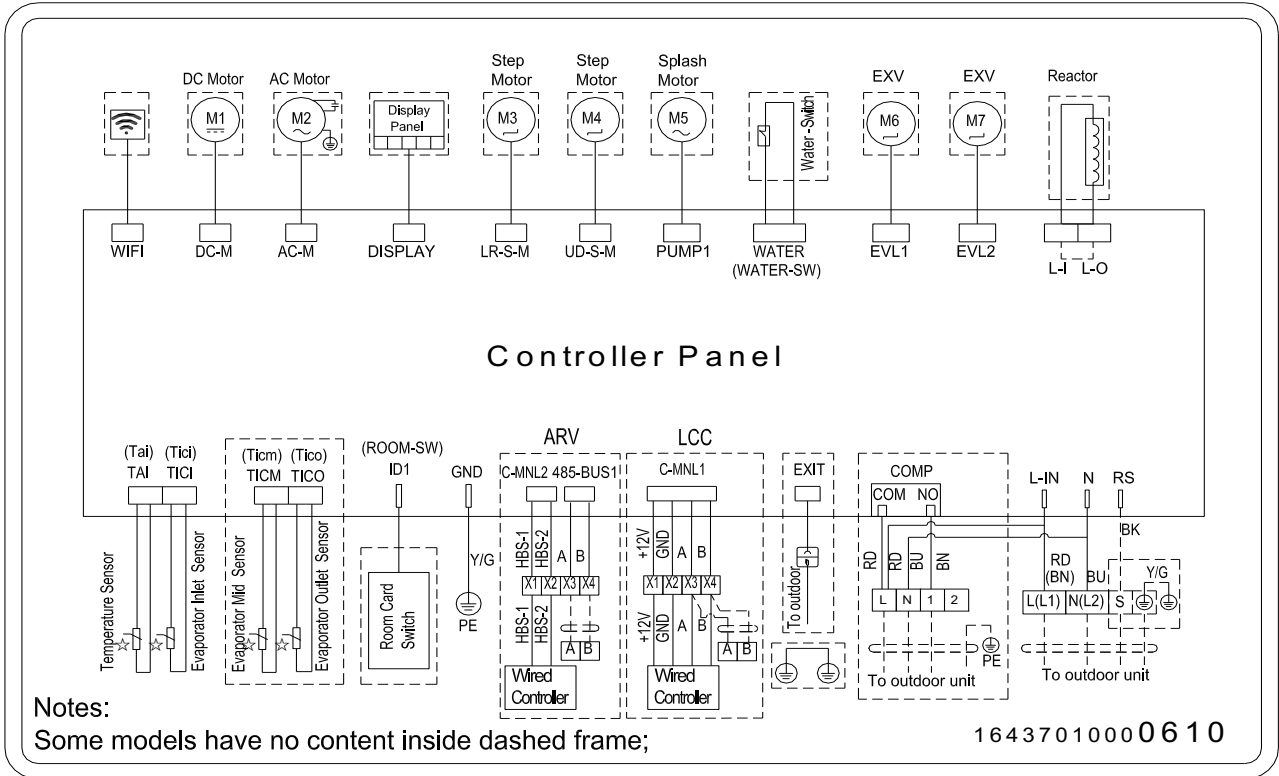

## 2. Ceiling Floor

AUCF-H18/4DR3HFA, AUCF-H24/4DR3HFA,

AUCF-H36/NDR3HFC, AUCF-H42/NDR3HFC, AUCF-H48/SDR3HFC, AUCF-H60/SDR3HFC

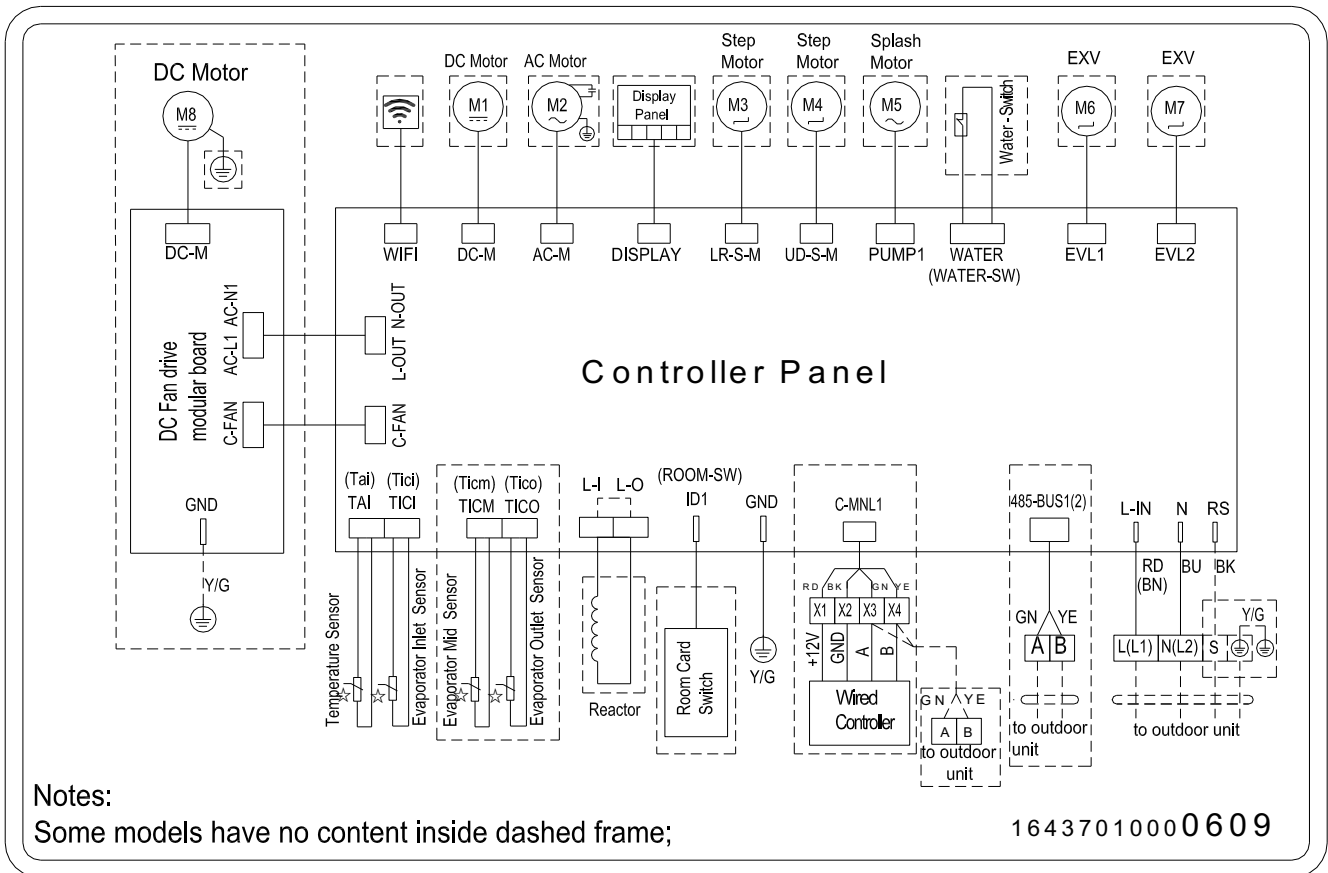

### 3. Duct

AUMD-H12/NDR3HM2B, AUMD-H18/NDR3HM2B, AUMD-H24/NDR3HM2B, AUMD-H30/NDR3HC,  
 AUMD-H36/NDR3HC, AUMD-H42/NDR3HC, AUMD-H48/SDR3HC, AUMD-H60/SDR3HC

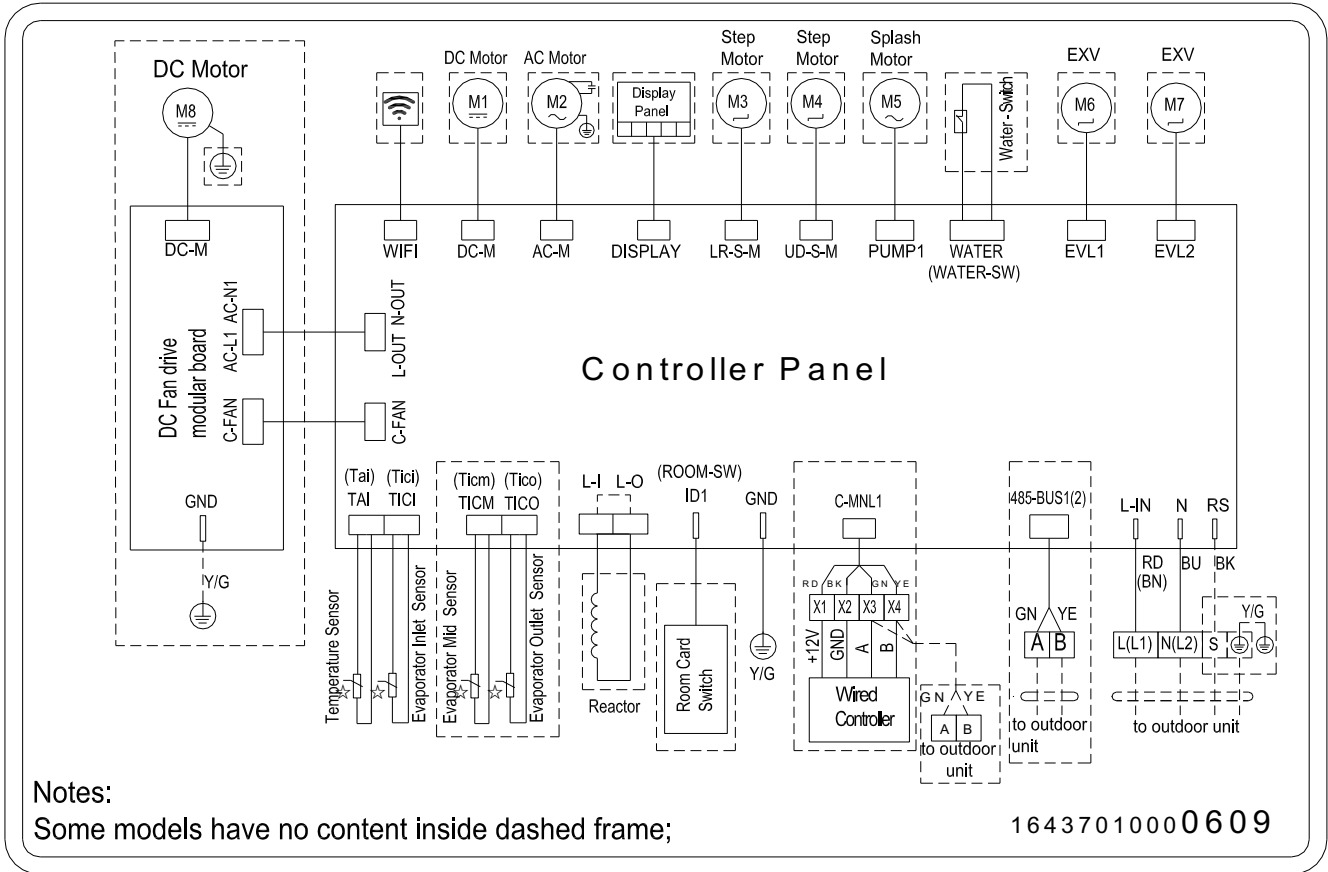

### 4. Console

AUCO-H12/4DR3HA、AUCO-H18/4DR3HA

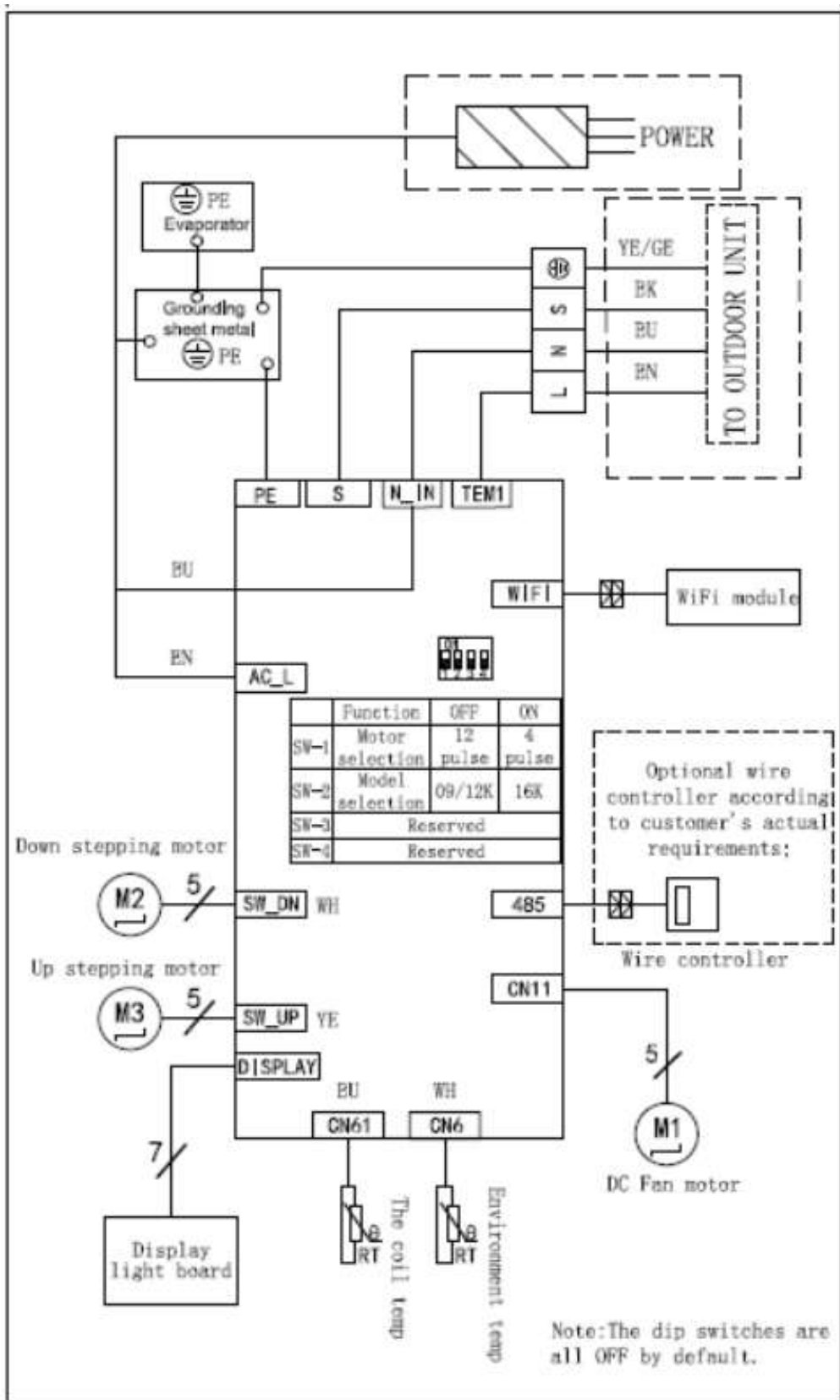

### 5. Outdoor Unit

AL-H12/NDR3HB2(U), AL-H18/NDR3HB2(U), AL-H24/NDR3HB2(U), AL-H30/NDR3HB2(U)

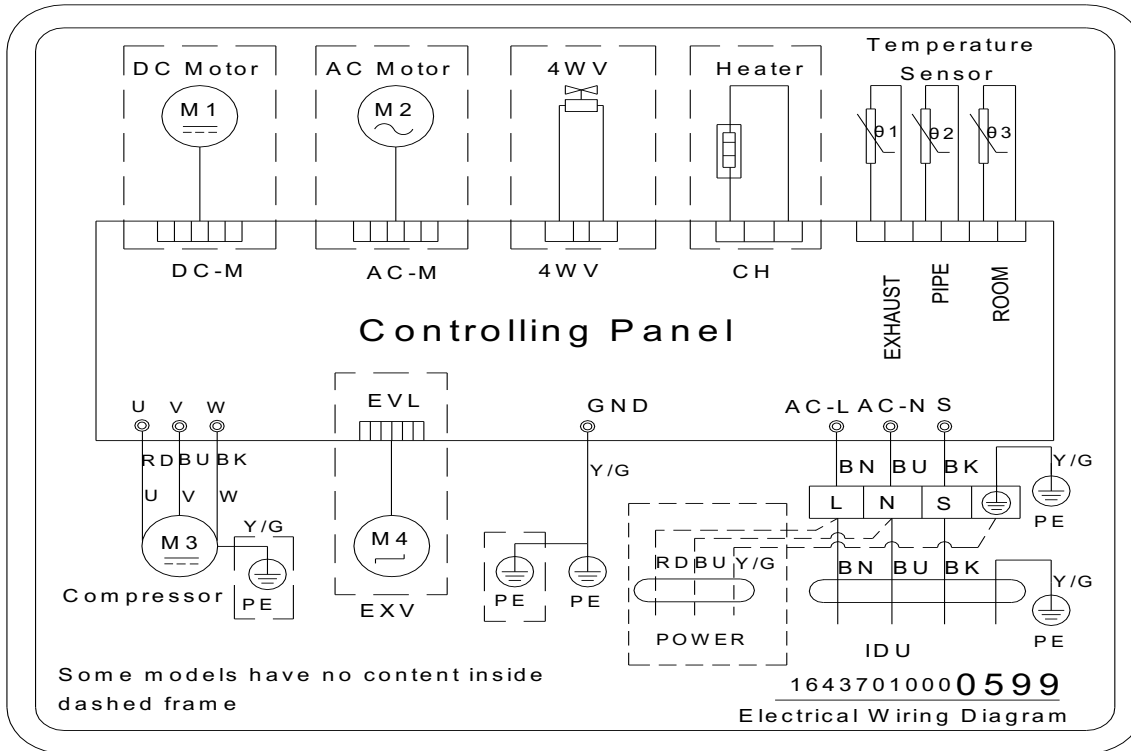

AL-H36/NDR3C2(U), AL-H42/NDR3C2(U)

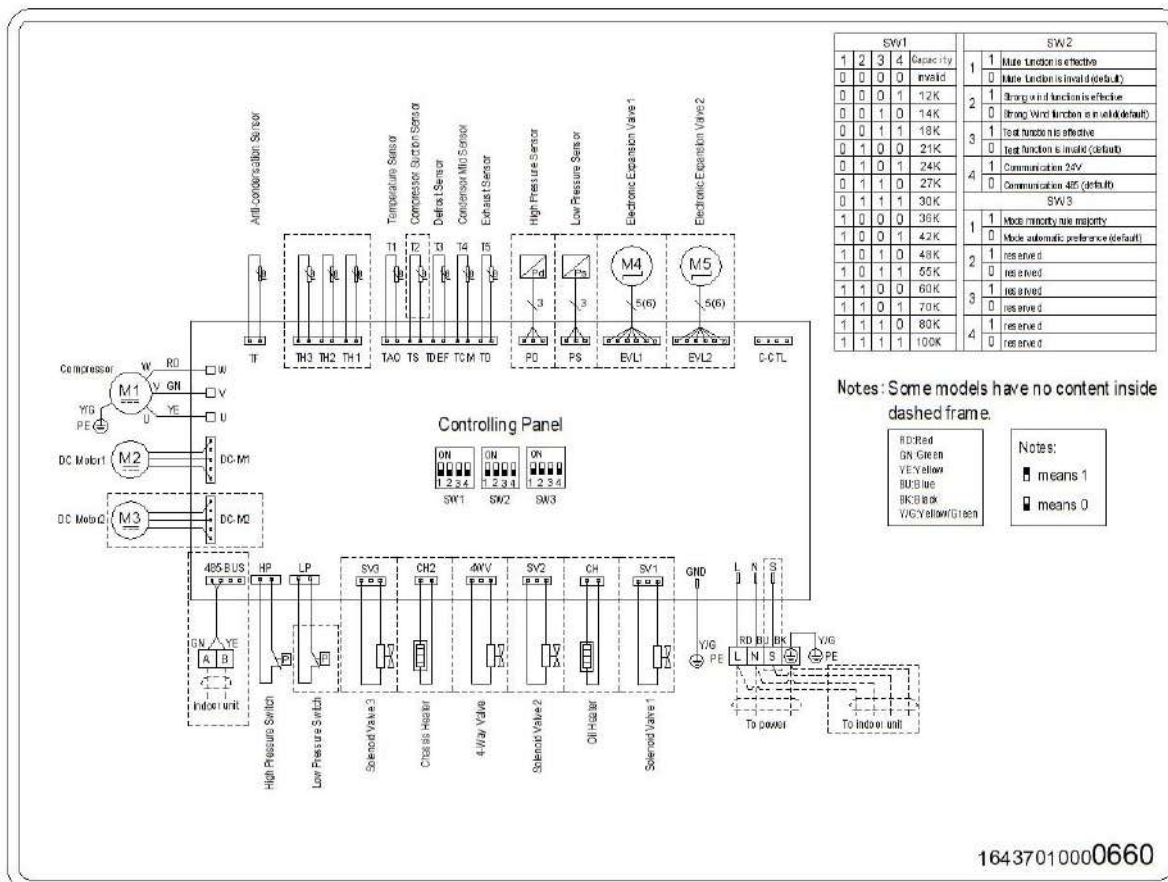

AL-H48/SDR3C2(U), AL-H60/SDR3C2(U)

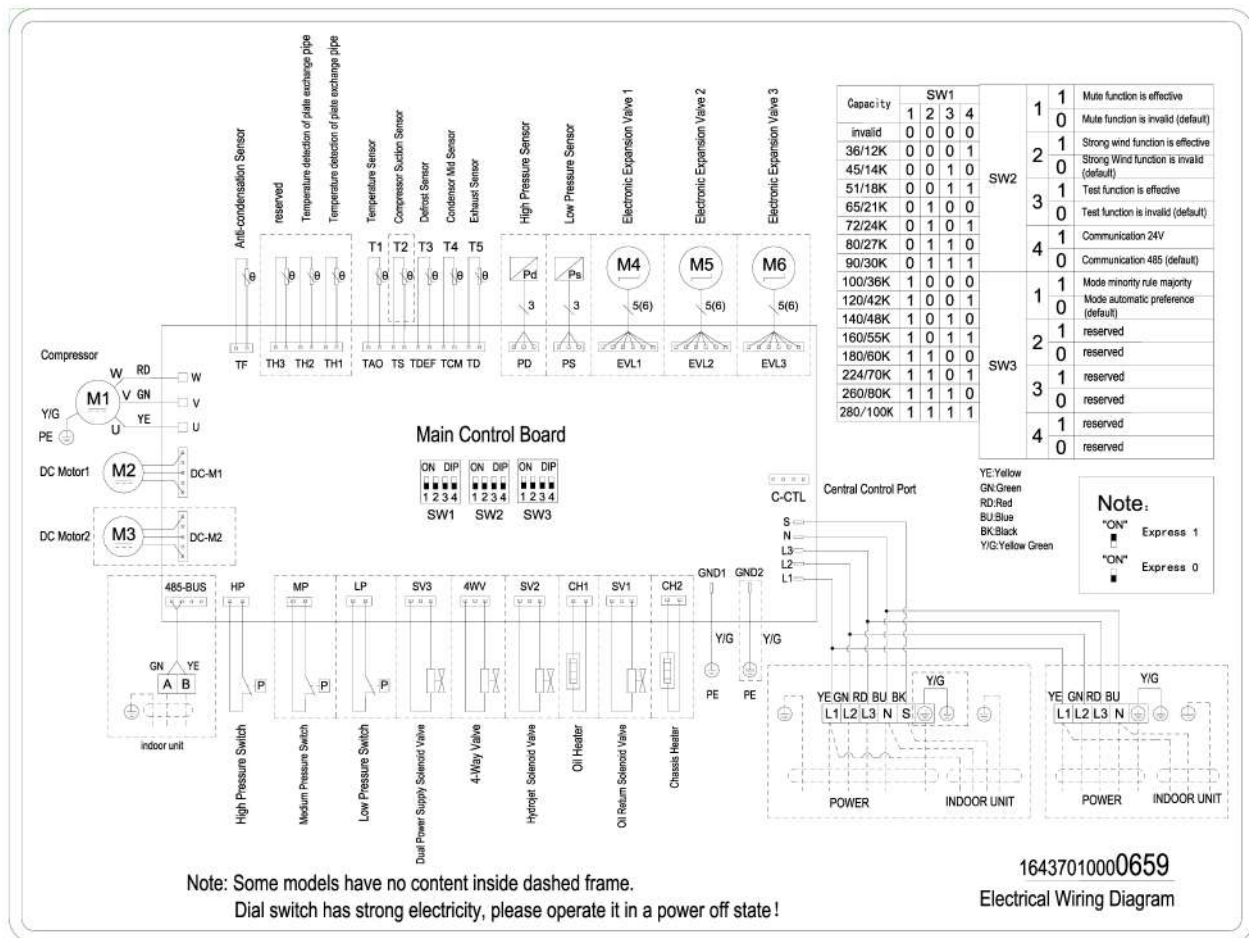

# Part6 Capacity Amendment

## 1. Operation range

Cooling capacity (K Btu/h)		12K	18K	24K	30K	36K	42K	48K	60K	
Power supply		220-240V~/50Hz						380-415V~/50Hz		
Voltage		187~242V						342~456V		
Ambient temperature	Cooling	-15~52°C								
	Heating	-15~24°C								

## 2. Capacity amendment of different ambient temperature

### 2.1 Amendment coefficient of Cooling capacity under different indoor/outdoor DB/WB temperature K1

IDU temp. °C		Outdoor air inlet DB temperature °C										
DB	WB	-10	0	10	16	25	30	35	40	43	48	52
23	16	1.19	1.12	1.08	1.05	1	0.95	0.90	0.87	0.85	0.82	0.77
25	18	1.26	1.19	1.12	1.08	1.05	1	0.95	0.90	0.87	0.85	0.82
27	19	1.28	1.26	1.19	1.12	1.08	1.05	1	0.95	0.90	0.87	0.85
28	20	1.30	1.28	1.26	1.19	1.12	1.08	1.05	1	0.95	0.90	0.87
30	22	1.33	1.30	1.28	1.26	1.19	1.12	1.08	1.05	1	0.95	0.90
32	24	1.5	1.33	1.30	1.28	1.26	1.19	1.12	1.08	1.05	1	0.95

Actual cooling capacity calculation:

Actual cooling capacity = amendment coefficient of cooling capacity × nominal cooling capacity

—— Rated cooling capacity could be found from **【Part 4 Specification】**

—— Amendment coefficient of cooling capacity could be found from table above.

**2.2 Amendment coefficient of Heating capacity under different indoor/outdoor DB/WB temperature K2**

IDU temp. °C	Outdoor air inlet DB temperature °C								
	DB	-15	-10	-5	0	7	10	15	20
16	0.93	0.97	1	1.06	1.08	1.1	1.14	1.2	1.25
18	0.87	0.93	0.97	1	1.06	1.08	1.1	1.14	1.2
20	0.8	0.87	0.93	0.97	1	1.06	1.08	1.1	1.14
22	0.71	0.8	0.87	0.93	0.97	1	1.06	1.08	1.1
24	0.62	0.71	0.8	0.87	0.93	0.97	1	1.06	1.08

Actual heating capacity calculation:

Actual heating capacity = amendment coefficient of heating capacity × nominal heating capacity

—— Rated heating capacity could be found from **【Part 4 Specification】**

—— amendment coefficient of heating capacity could be found from table above.

**3. Long piping length**

Cooling capacity (K Btu/h)		12K	18K	24K	30K	36K	42K	48K	60K
Connection Pipe(mm)	Liquid pipe	Φ6.35		Φ9.52			Φ9.52		
	Gas pipe	Φ12.7		Φ15.88			Φ19.05		
Max. connecting liquid pipe (m)		Φ7.94		9.52			12.7		
Max. connecting gas pipe (m)		Φ15.88		19.05			22.2		
Max. piping length(m)		25	30	50		65			
Max. piping height(m)		10	20	25		30			
Max. Bend Qty		3	5	8			10		
Charge additional refrigerant (kg/m)		0.03		0.05					

**Caution:**

1. The standard Pipe length is 5m, if the pipe length is less than this then no additional charging is necessary. If the pipe length is more than this then you should charge more refrigerant into the system according to the above Charging Data

- 2. The thickness of the pipe is 0.6-1.0, bearing pressure is 4.2MPa;
- 3. If the connection pipe is too long, the cooling capacity and stability would be decreased. And the more bend quantity, the resistance in the piping system would be bigger, then the cooling and heating capacity would be decreased even lead to compressor broken. We suggest you to use the shortest connection pipe according to the pipe length parameter in this manual. If the height difference between outdoor and indoor unit is more than 5m, an oil trap should be installed in the gas pipe for every 8-10 meters.

### 4. Capacity amendment of different piping length

#### 4.1 Amendment coefficients

Amendment coefficients of heating and cooling capacity under different height drop **K3**

**Different Cooling Capacity modified coefficients at different height:**

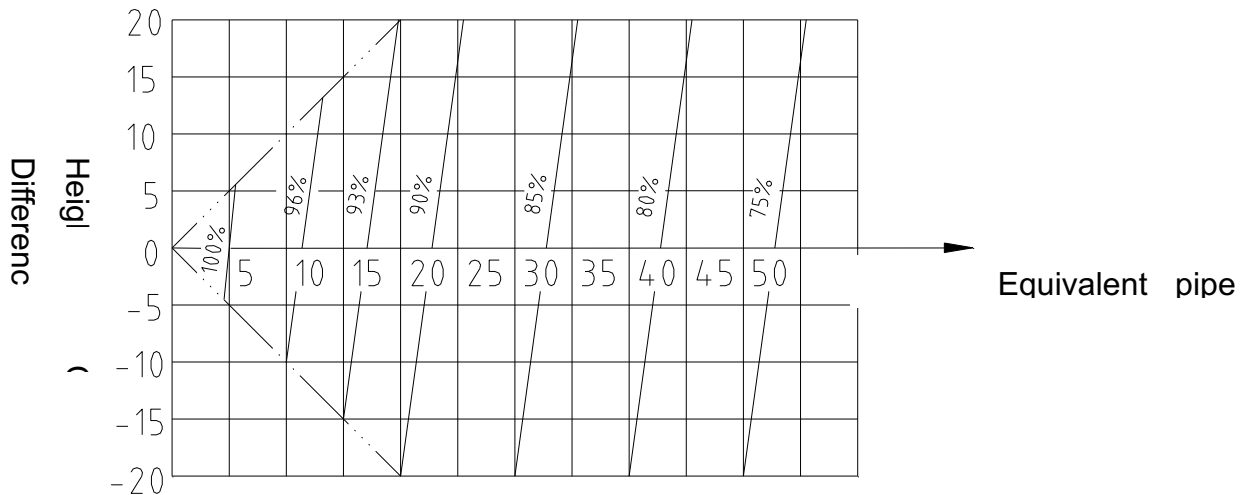

**Note:**

H = Height of Outdoor Unit — Height of Indoor Unit

**Different Heating Capacity modified coefficients at different height:**

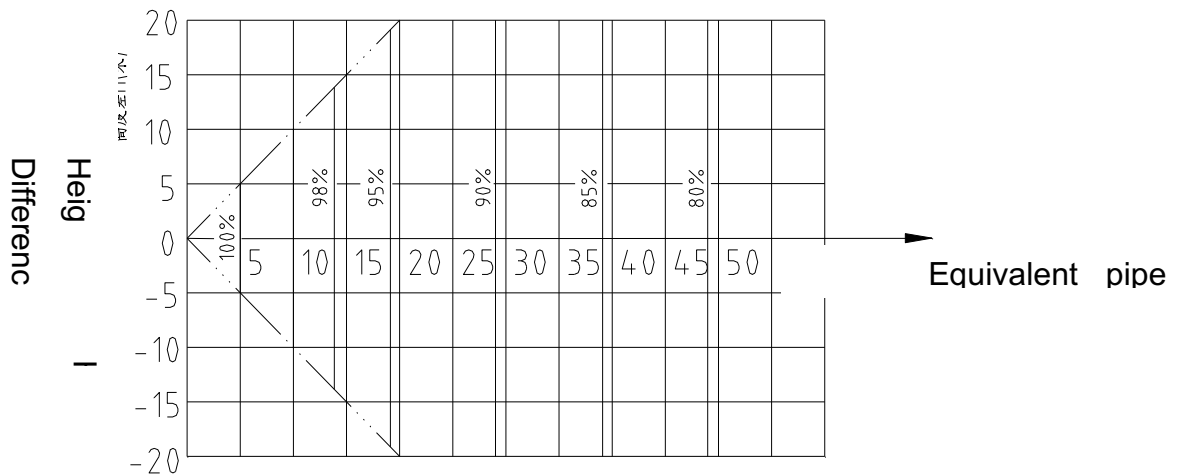

**Note:**

H = Height of Outdoor Unit — Height of Indoor Unit

**4.2 Correction capability**

Cooling capacity = Rated cooling capacity xK1xK3

Heating capacity = Rated heating capacity xK2xK3

**5. Equivalent Pipe length conversion**

Equivalent pipe length means converting pipe elbow to straight pipe length after considerate the pressure loss.

**Bend and Oil Loop Conversion tablet**

Pipe Dia.(mm) \ Type	Bend ( m )	Oil Loop(m)
6.35	0.10	0.7
9.52	0.18	1.3
12.70	0.20	1.5
15.88	0.25	2.0
19.05	0.35	2.4
22.02	0.40	3.0

Equivalent Pipe length L=Actual Pipe length L+ Bend Qty× Equivalent pipe bend length+ Oil Loop Qty × Equivalent Oil Loop length

**Sample:**

ALCA-H42/5 Actual Pipe length is 25meters, Gas pipe diameter is 15.88mm. If there's 5 bends and 2 oil loops during the installation, then the equivalent pipe length should be:

$$L=25+0.25 \times 5 + 2.0 \times 2 = 30.25(m)$$

**Note:**

If the height difference between outdoor and indoor unit is more than 5m, an oil trap should be installed in the gas pipe for every 8-10 meters.

# Part7 Static pressure curve

## 1. AUMD-H12/NDR3HM2B

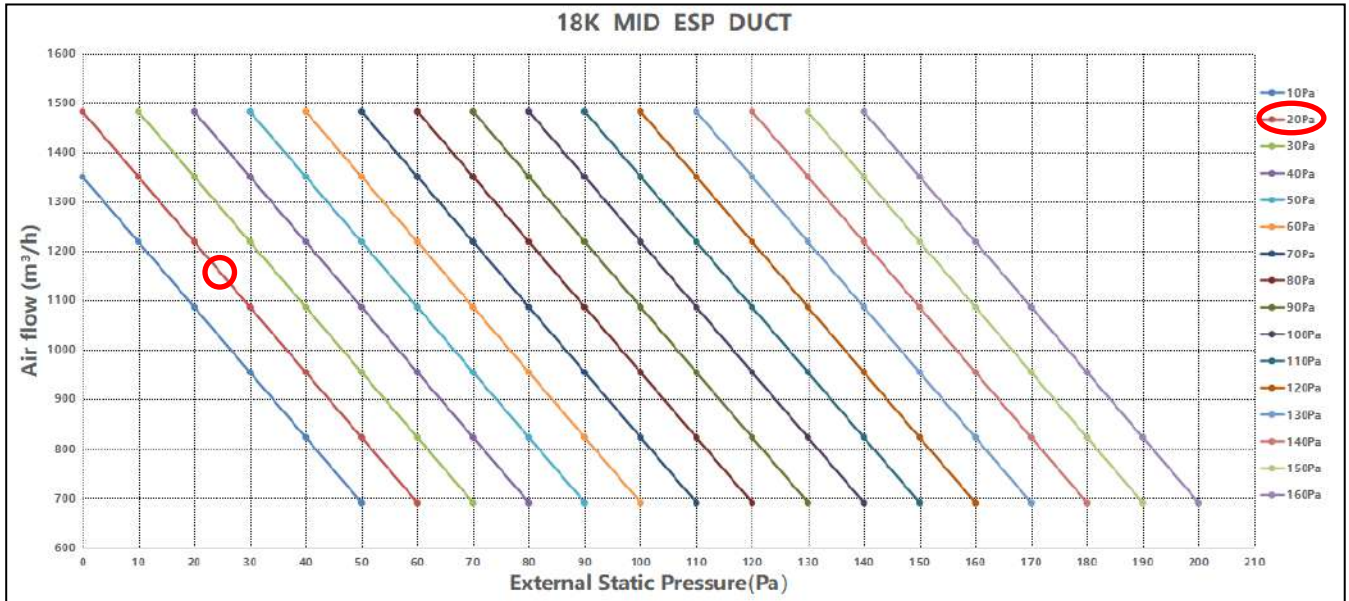

## 2. AUMD-H18/NDR3HM2B

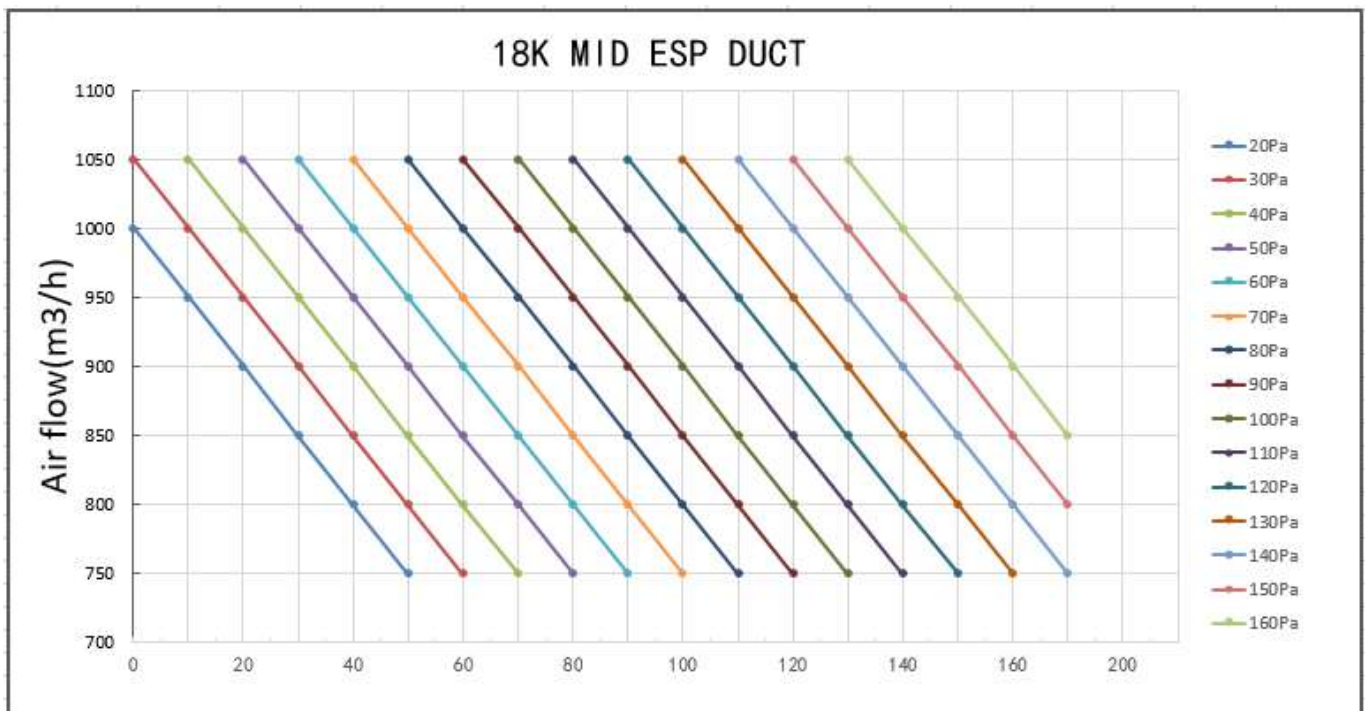

### 3. AUMD-H24/NDR3HM2B

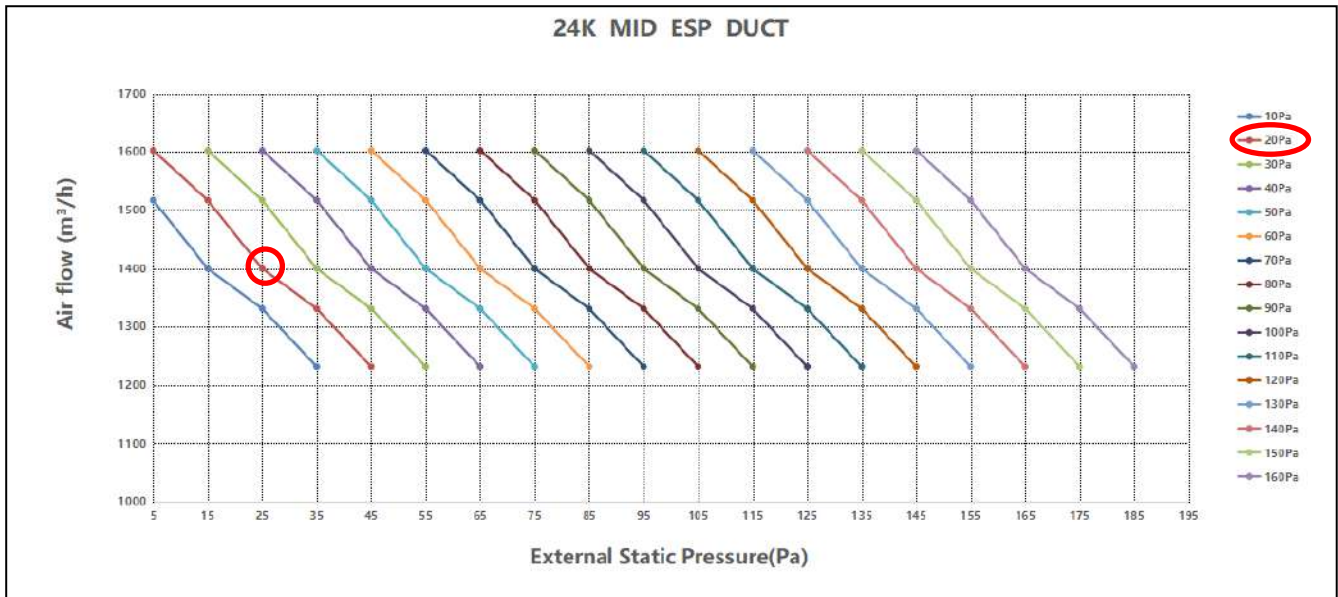

### 4. AUMD-H30/NDR3HC

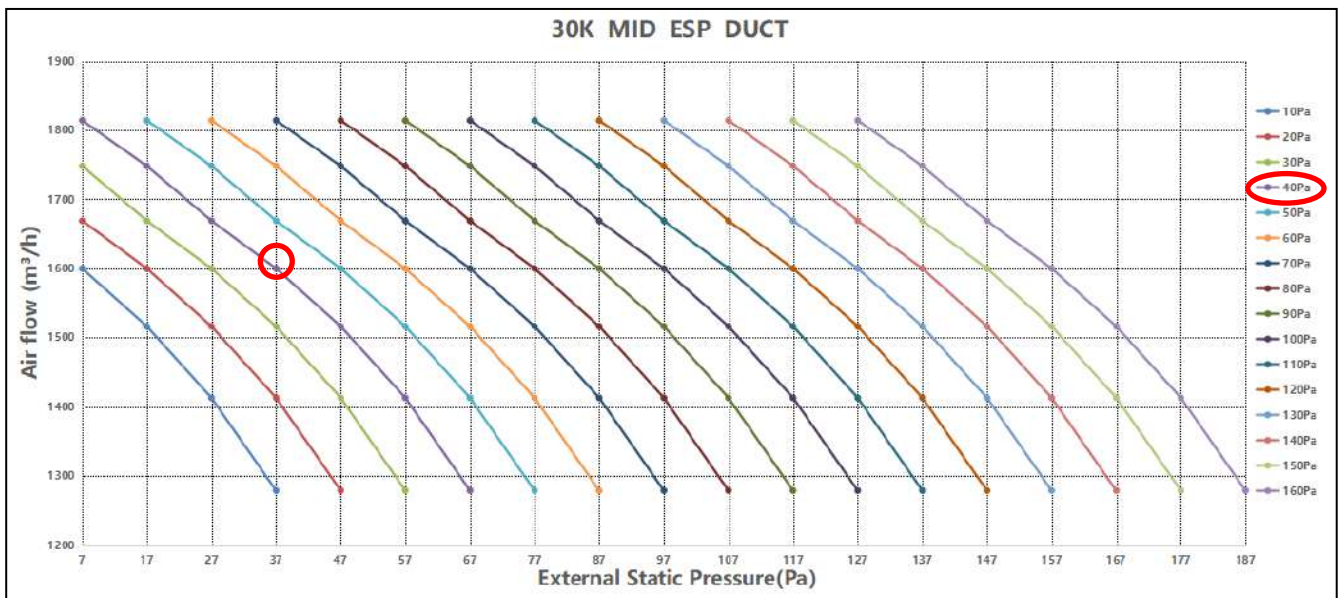

### 5. AUMD-H36/NDR3HC, AUMD-H42/NDR3H

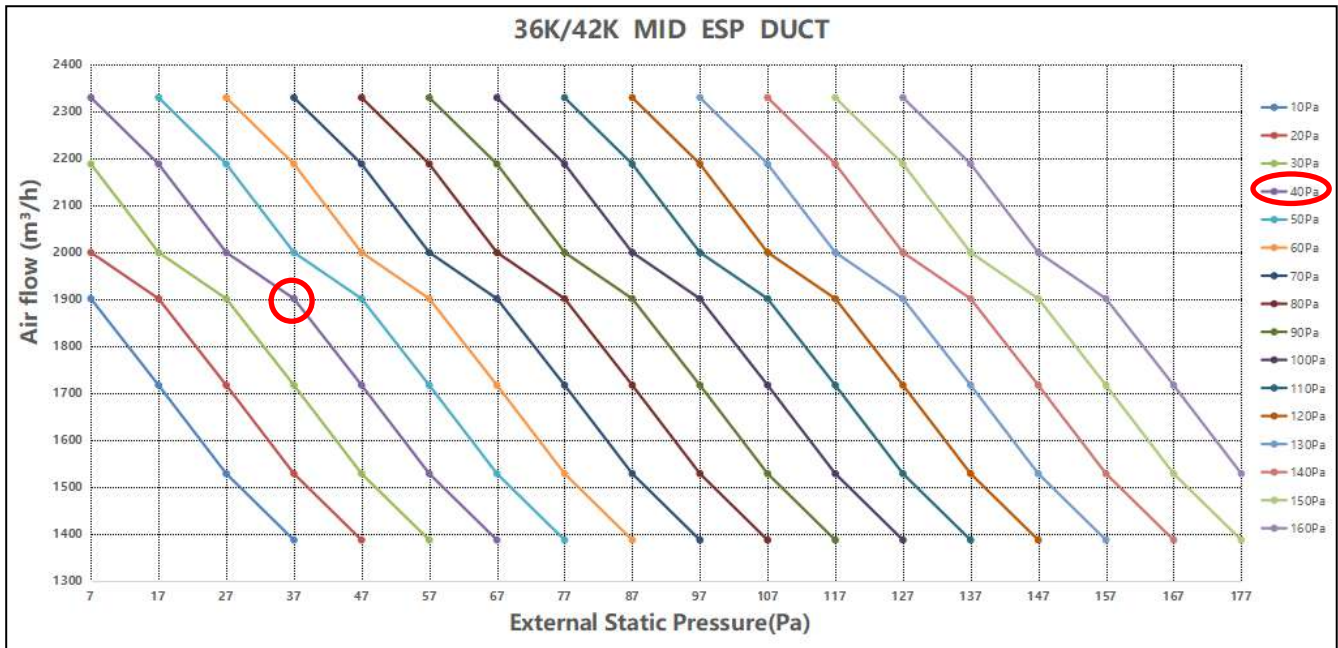

### 6. AUMD-H48/SDR3HC, AUMD-H60/SDR3HC

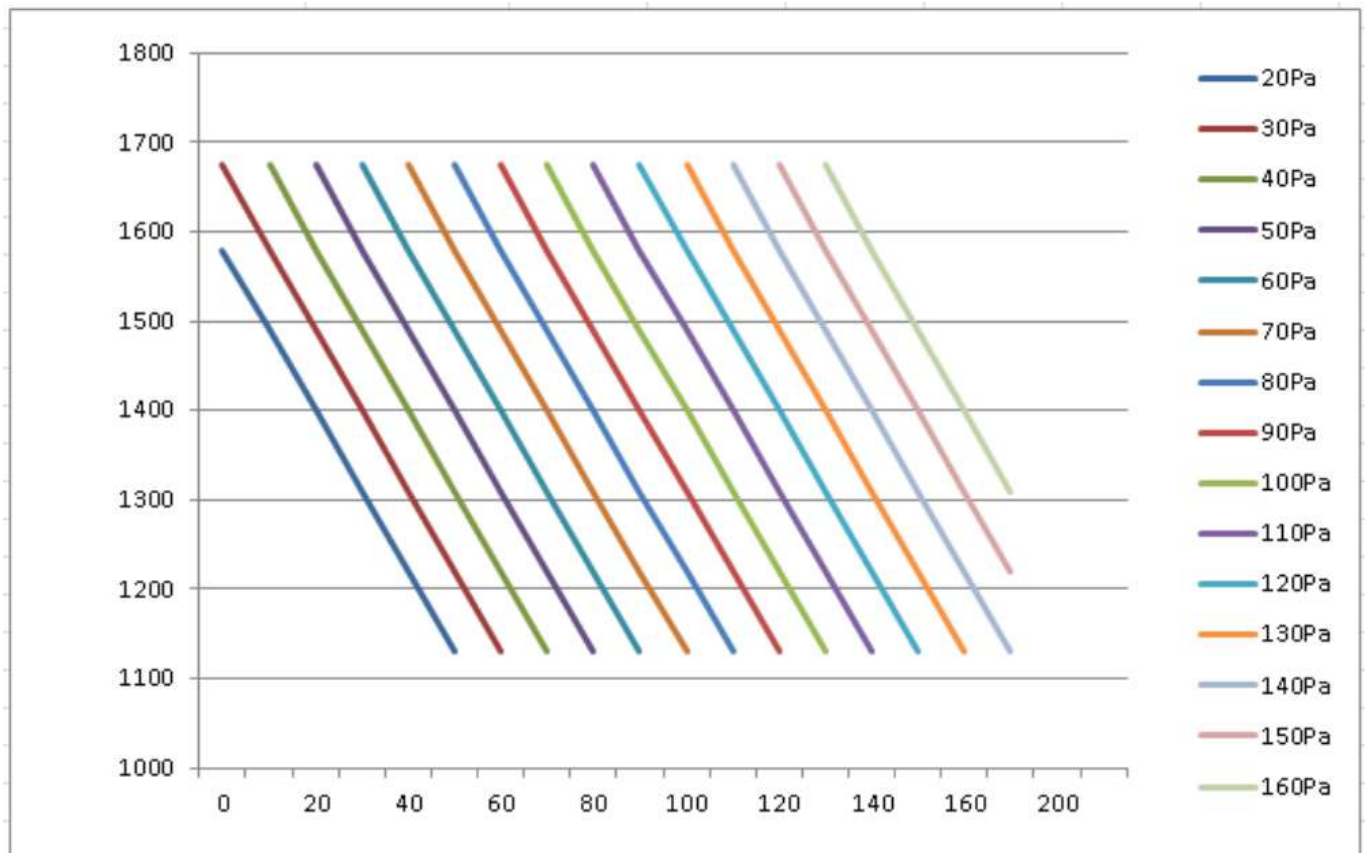

## Part8 Sound level

### 1. Outdoor unit

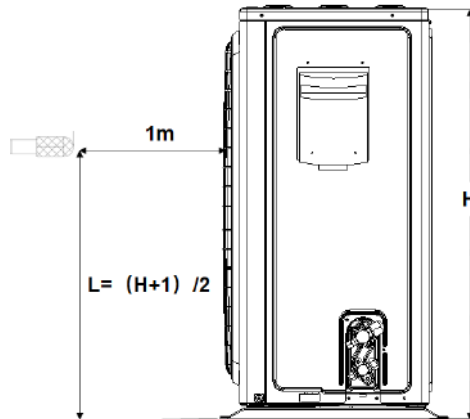

**Test site: 1m directly in front of the air outlet**

Model	Sound pressure (dB (A) )
AL-H12/NDR3HB2(U)	54
AL-H18/NDR3HB2(U)	55
AL-H24/NDR3HB2(U)	58
AL-H30/NDR3HB2(U)	58
AL-H36/NDR3C2(U)	59
AL-H42/NDR3C2(U)	60
AL-H48/SDR3C2(U)	60
AL-H60/SDR3C2(U)	60

2. Duct

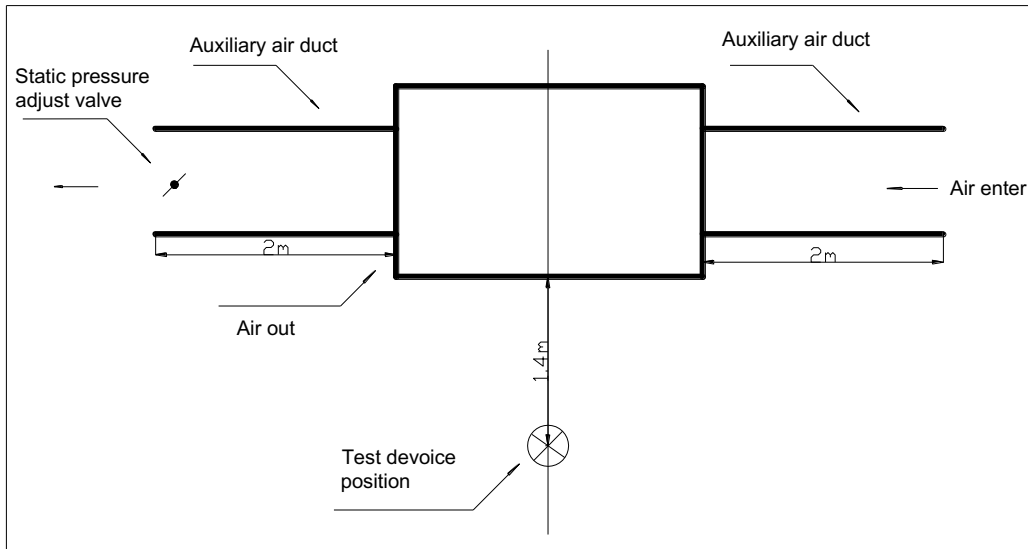

Test site: 1.4m directly below the center of the duct

	Models	Noise level under three speeds of fan (dB(A))		
		H	M	L
<b>M Series</b>	AUMD-H12/NDR3HM2B	37	34	32
	AUMD-H18/NDR3HM2B	44	41	37
	AUMD-H24/NDR3HM2B	43	41	39
	AUMD-H30/NDR3HC	46	44	41
	AUMD-H36/NDR3HC	44	42	41
	AUMD-H42/NDR3HC	44	42	41
	AUMD-H48/SDR3HC	52	45	43
	AUMD-H60/SDR3HC	52	47	45

NC curves

AUMD-H12/NDR3HM2B

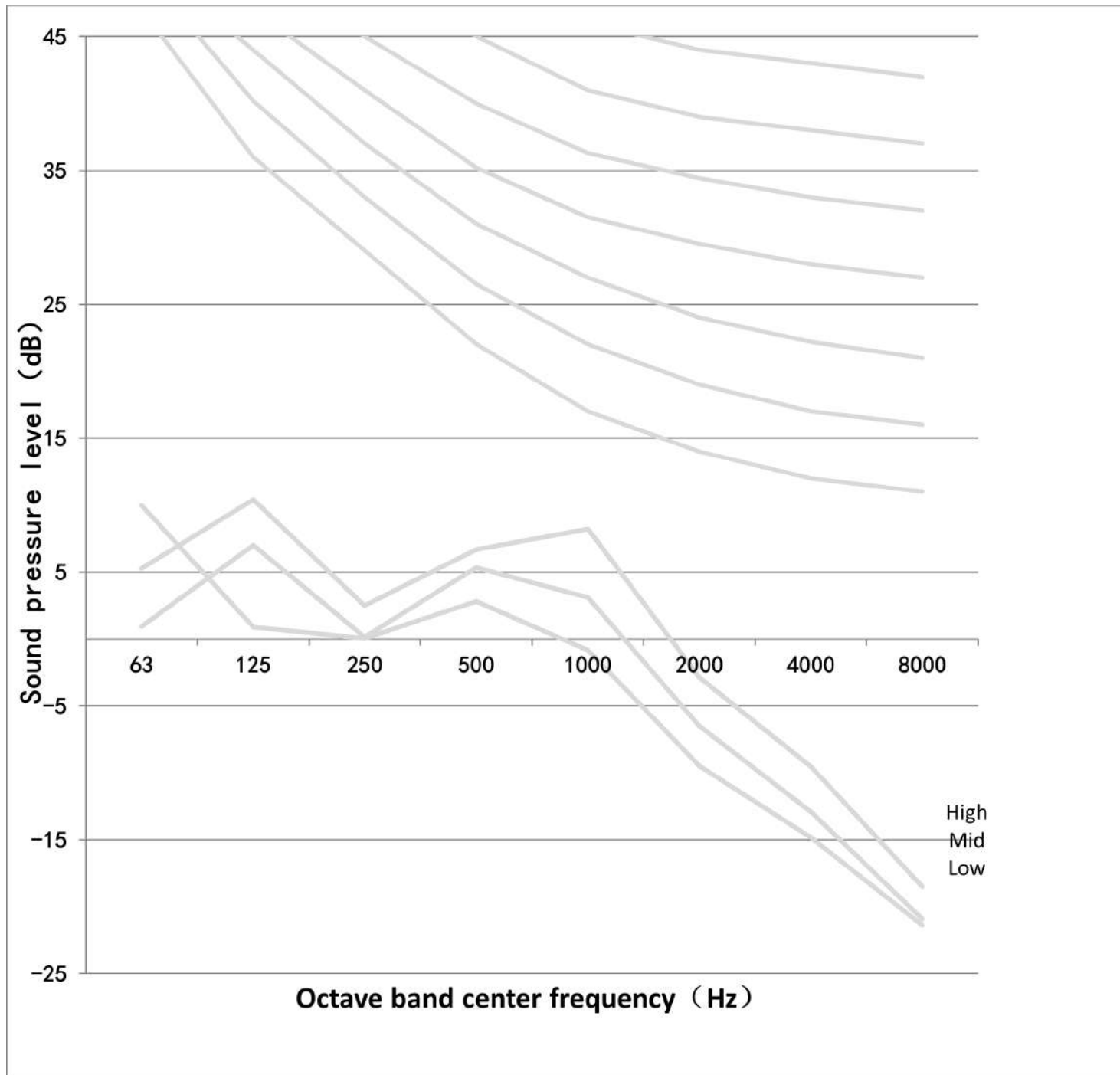

AUMD-H18/NDR3HM2B

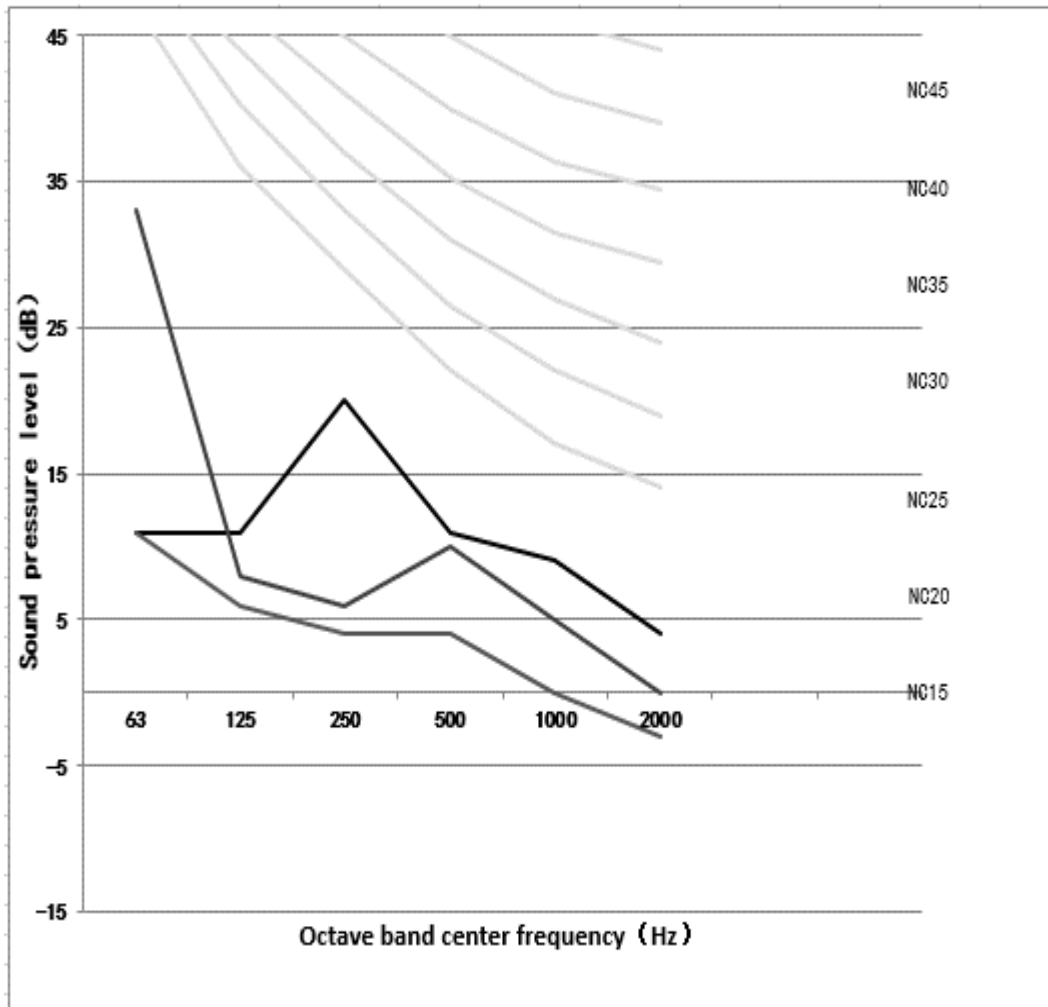

AUMD-H24/NDR3HM2B

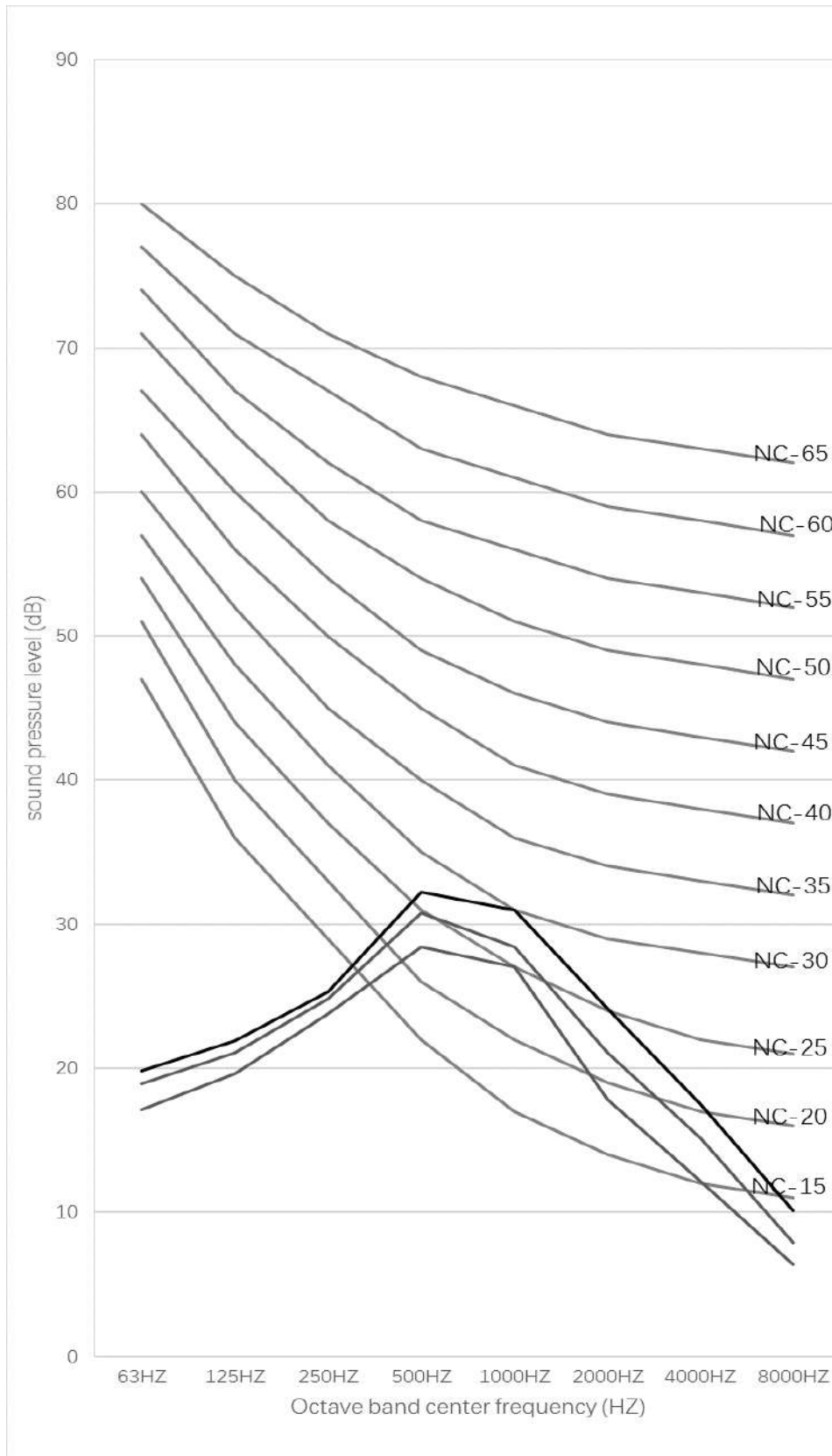

AUMD-H30/NDR3HC

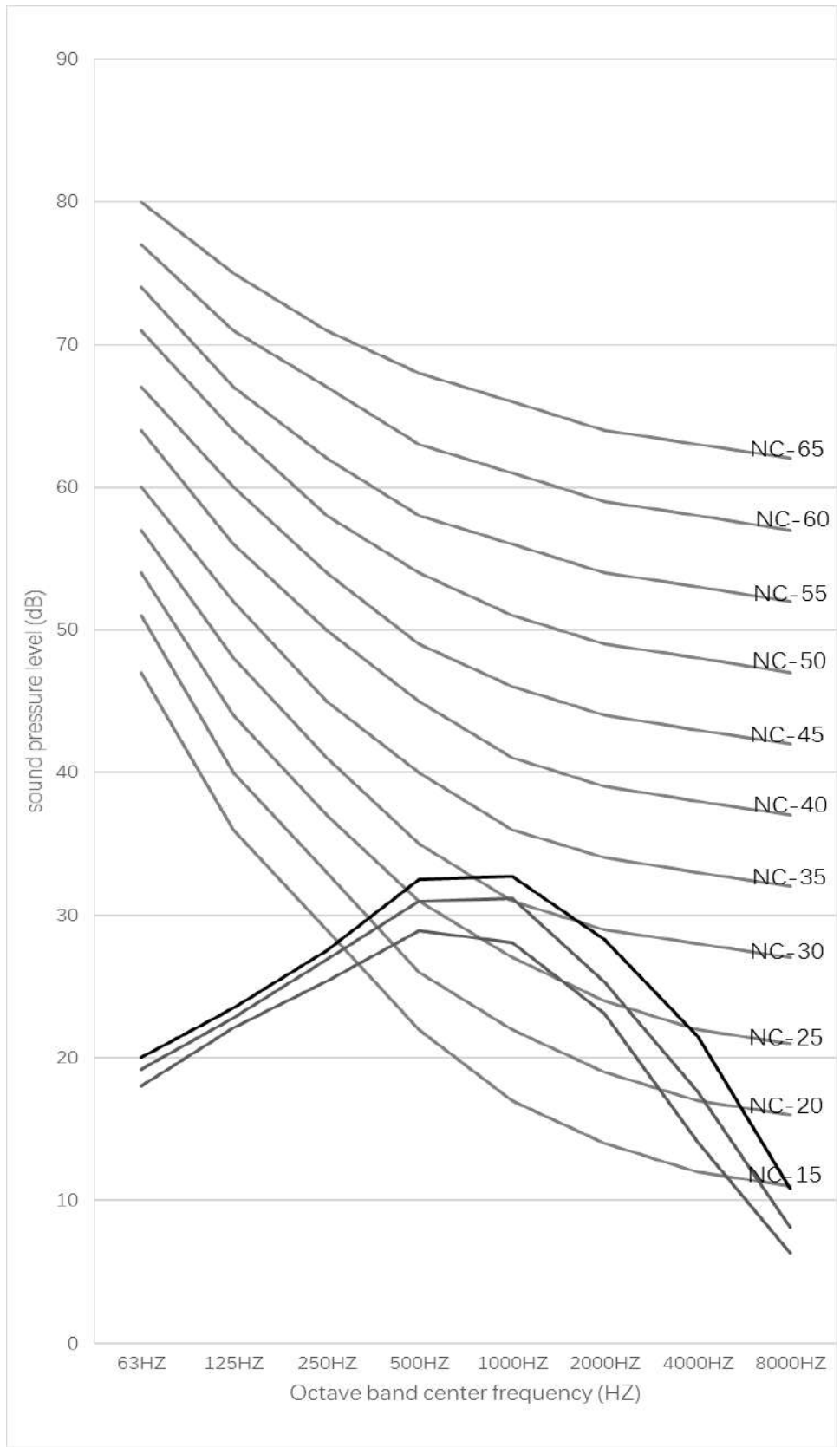

AUMD-H36/NDR3HC, AUMD-H42/NDR3HC

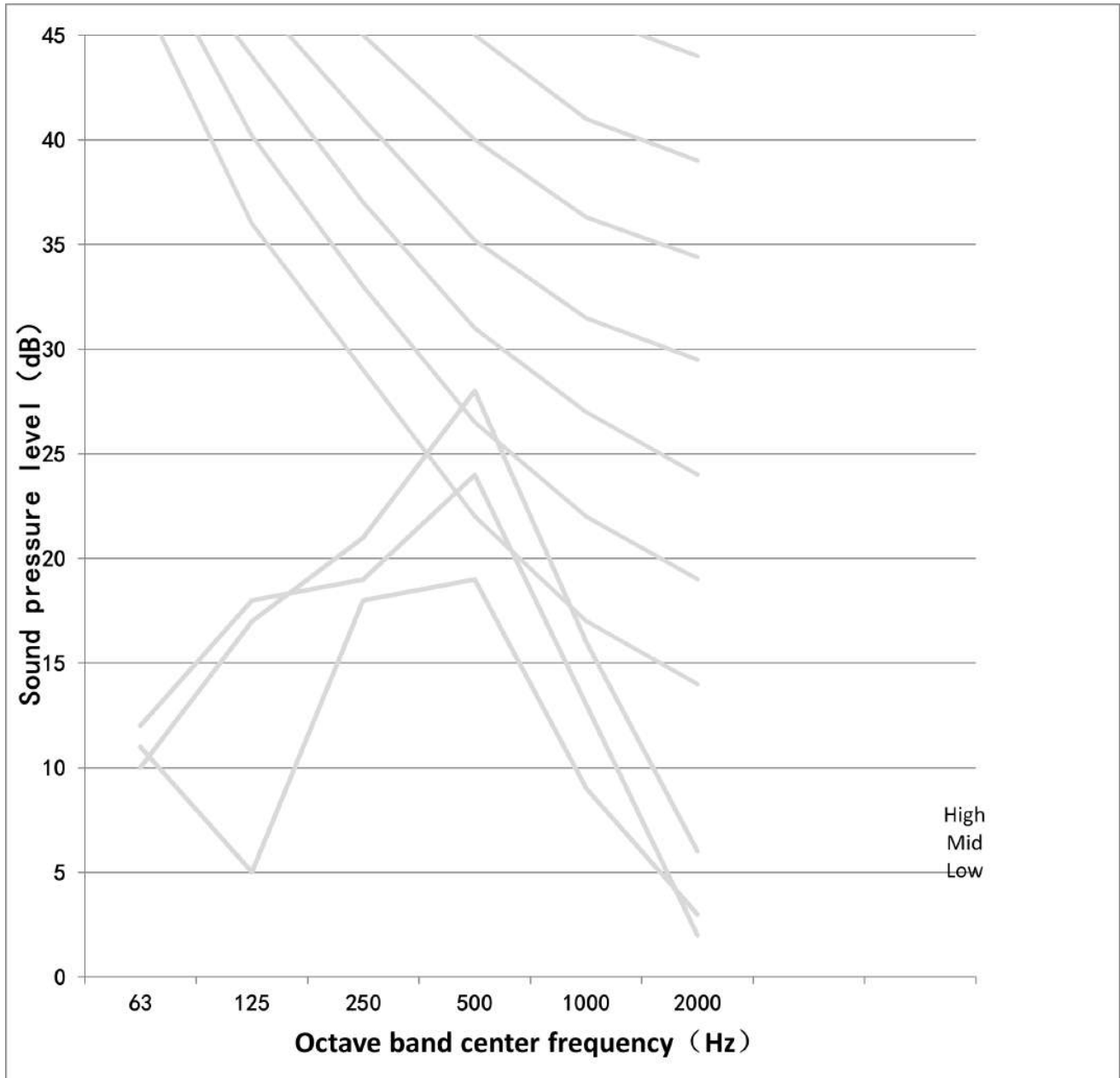

AUMD-H48/SDR3HC

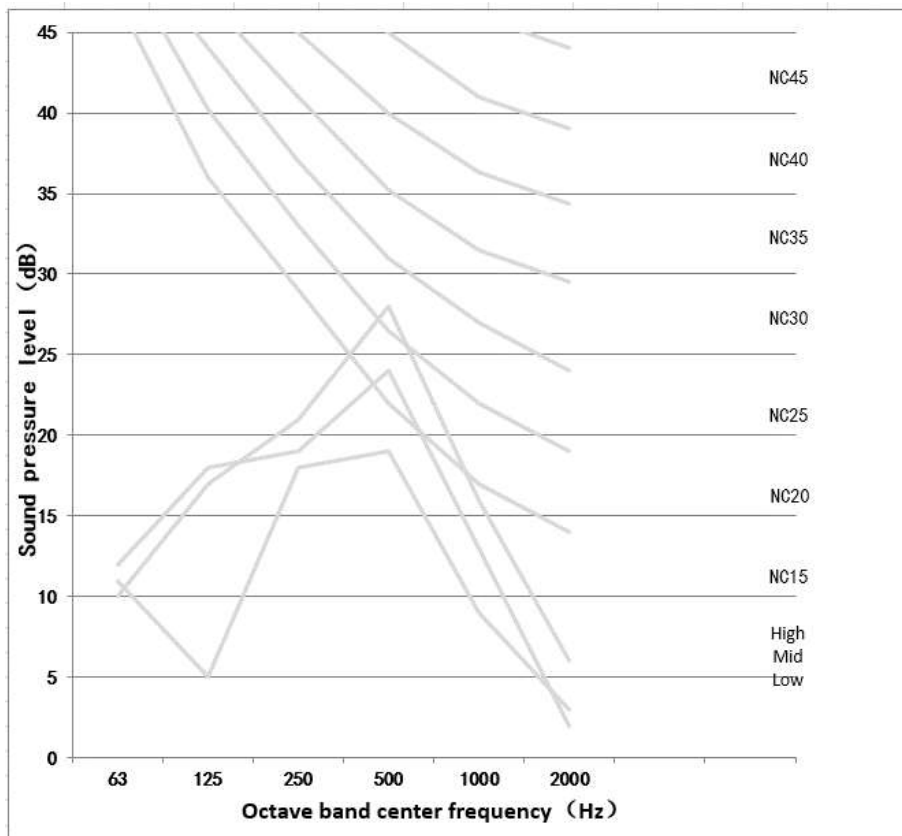

AUMD-H60/SDR3HC

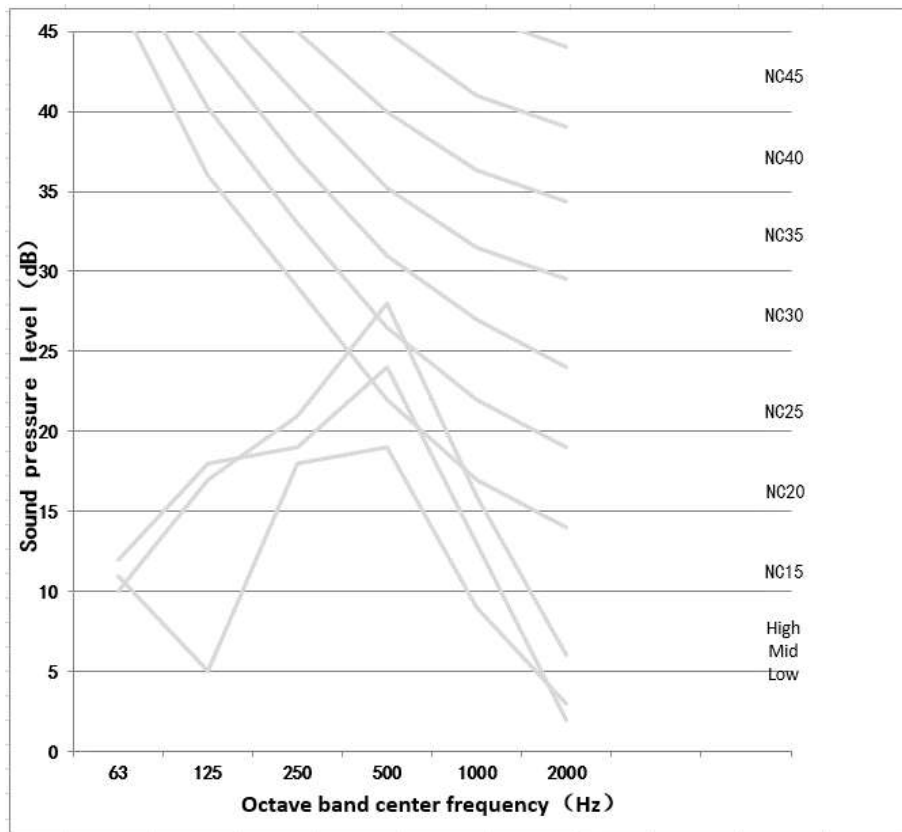

### 3. Cassette

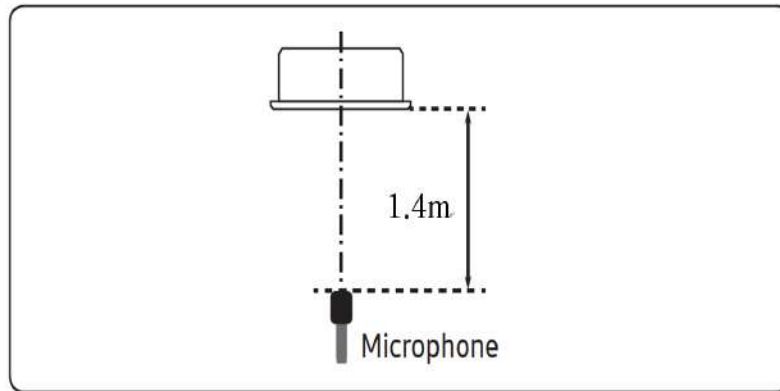

**Test site: 1.4m directly below the center of the duct**

	Models	Noise level under three speeds of fan (dB(A))		
		H	M	L
<b>Y Series</b>	AUCA-H12/4DR3HYAB	42	38	35
	AUCA-H18/4DR3HYAB	44	41	38
	AUCA-H24/4DR3HYAB	46.5	45	43
	AUCA-H36/NDR3HYCB	52	50	48
	AUCA-H42/NDR3HYCB	52	58	48
	AUCA-H48/SDR3HYCB	51	49	47
	AUCA-H60/SDR3HYCB	53	49	47

NC curves

AUCA-H12/4DR3HYAB

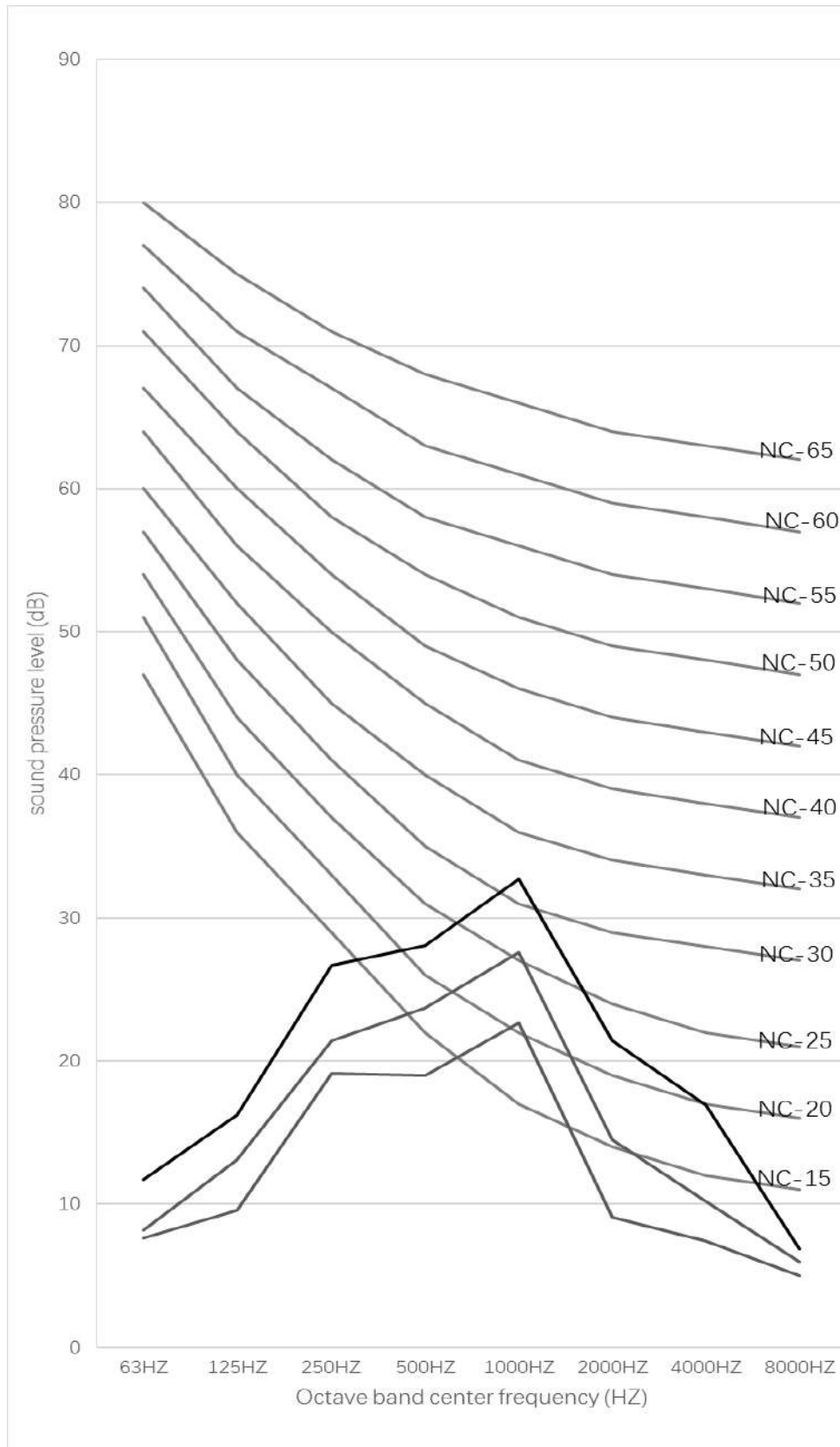

AUCA-H18/4DR3HYAB

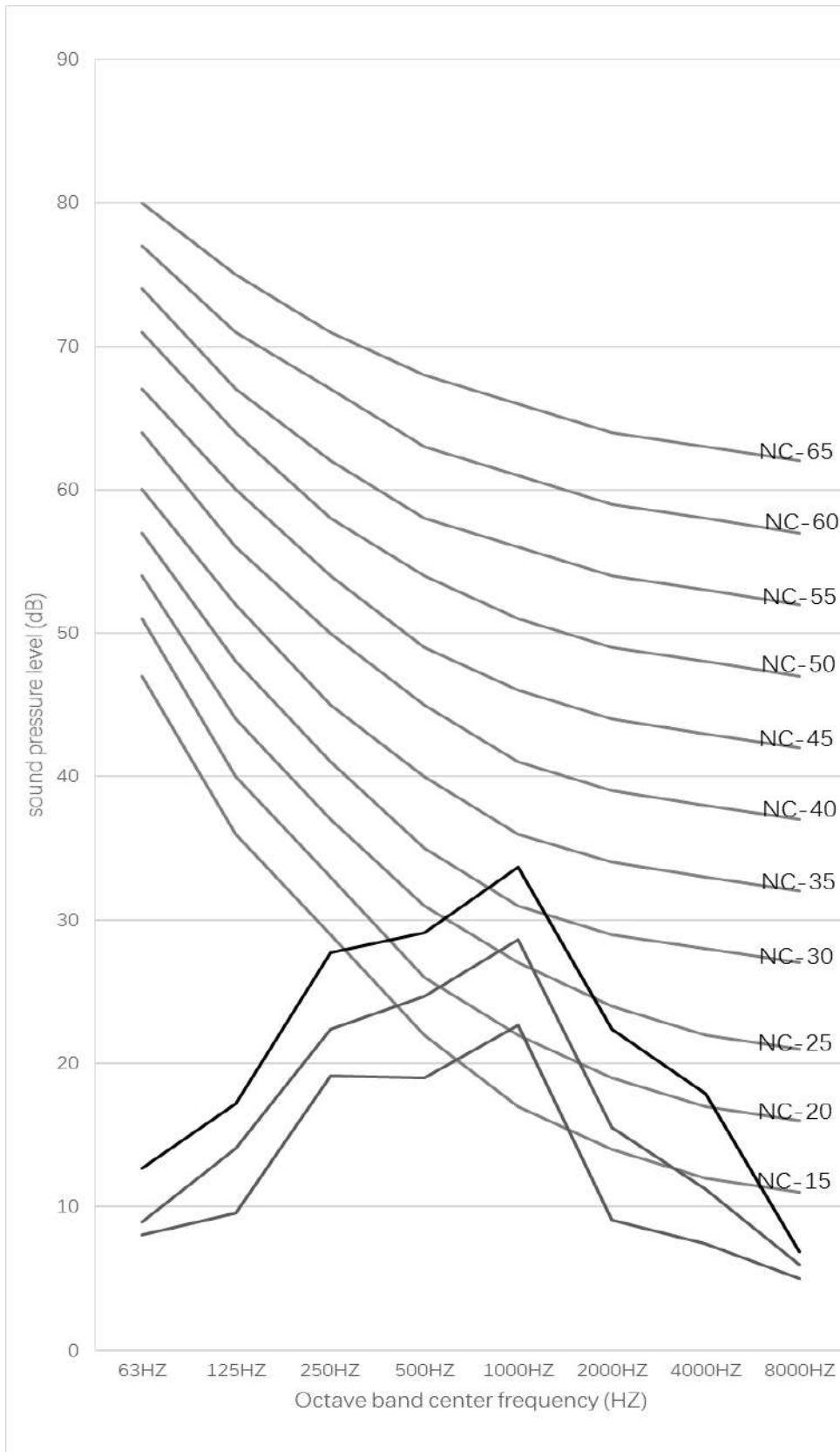

AUCA-H24/4DR3HYAB

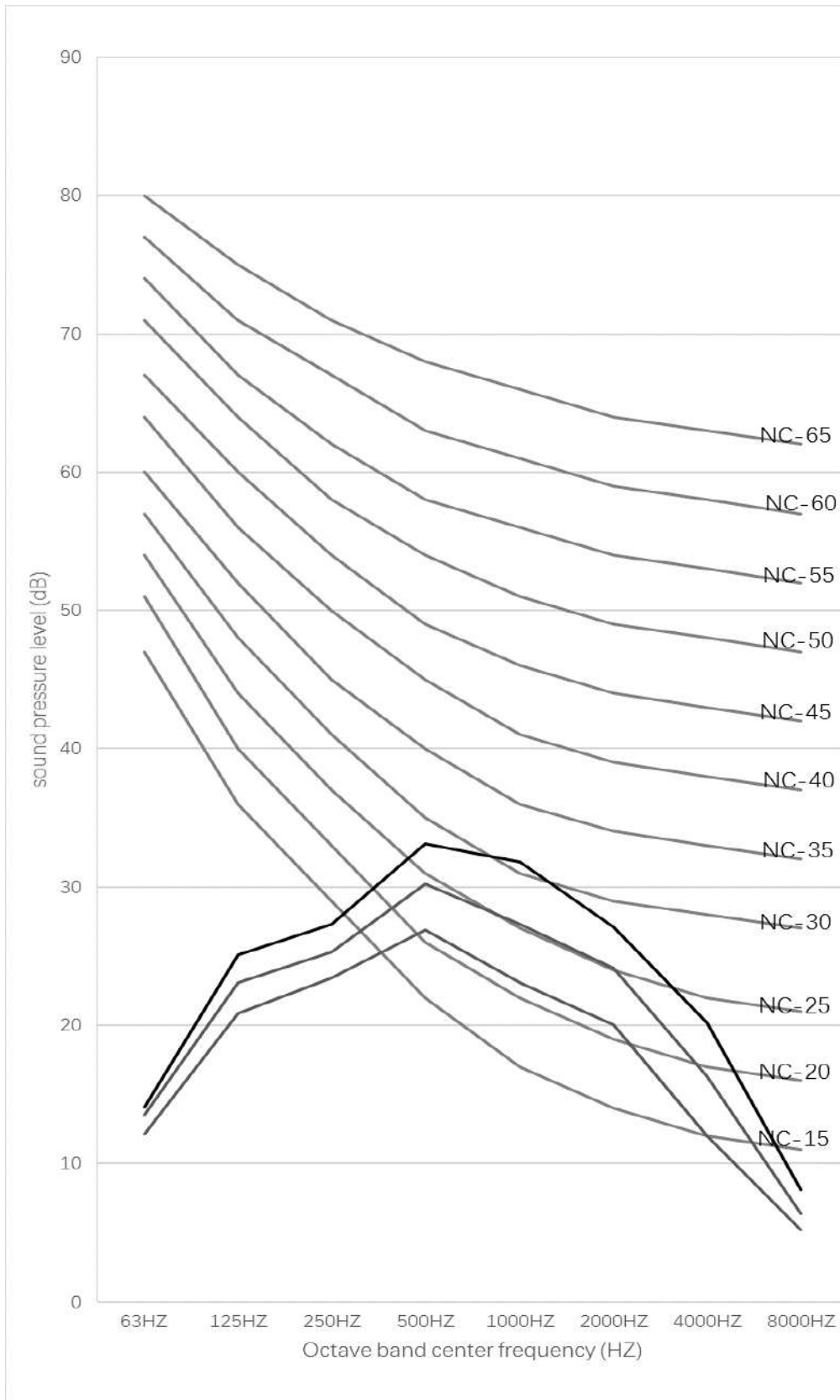

AUCA-H36/NDR3HYCB, AUCA-H42/NDR3HYCB

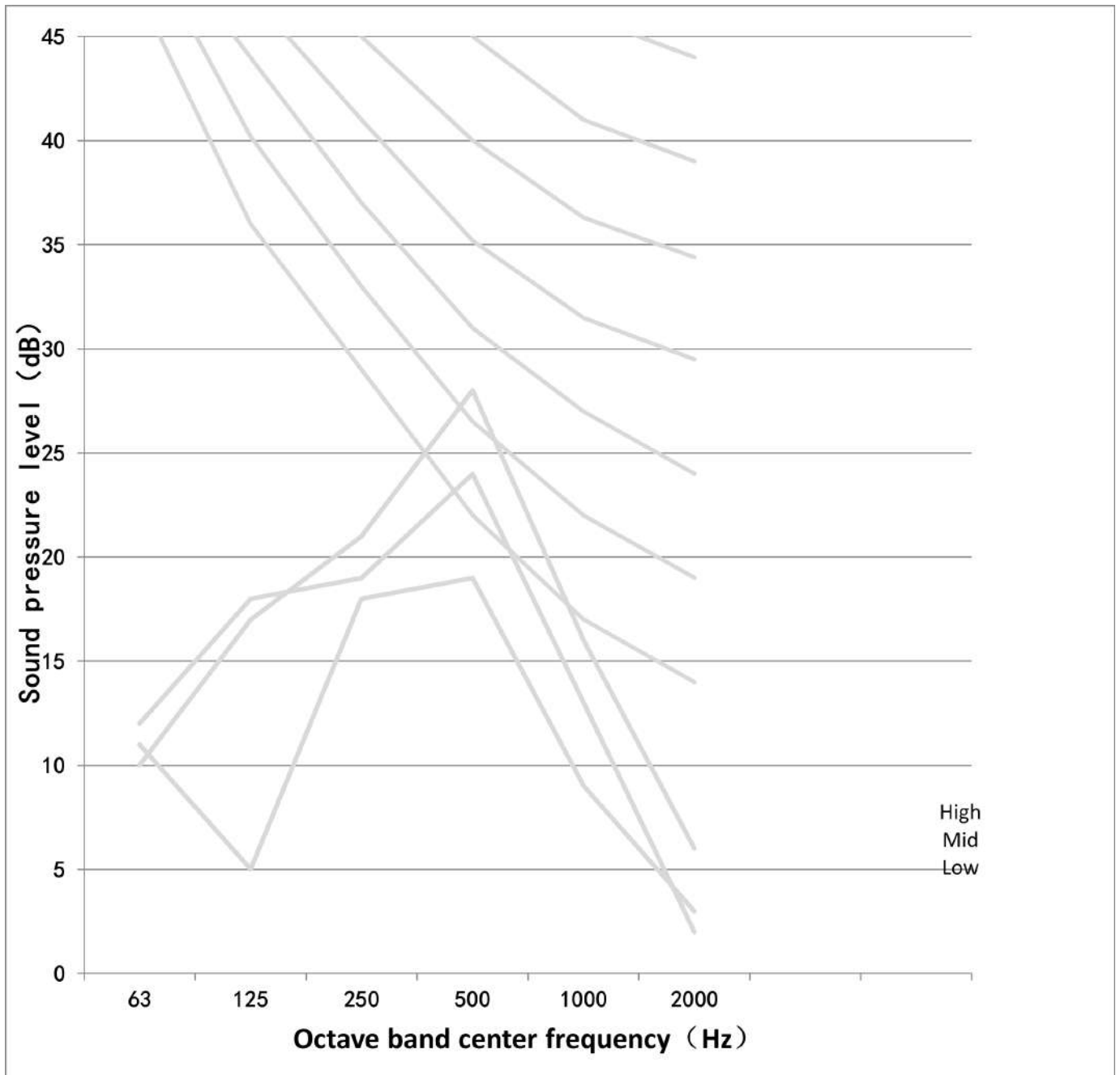

**AUCA-H48/SDR3HYCB**

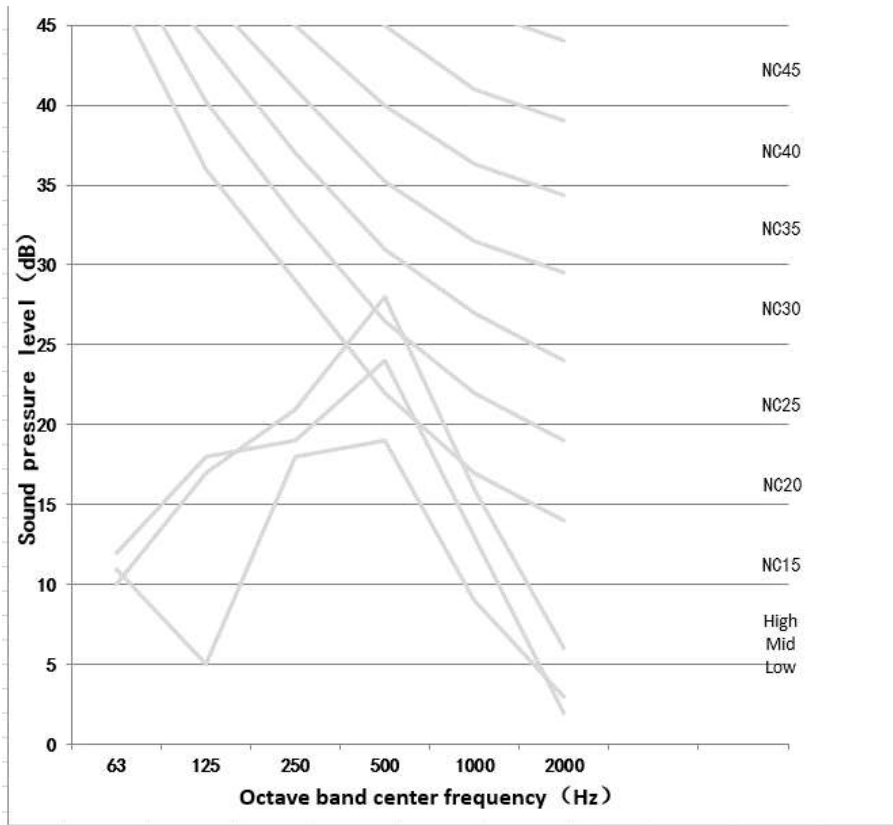

**AUCA-H60/SDR3HYCB**

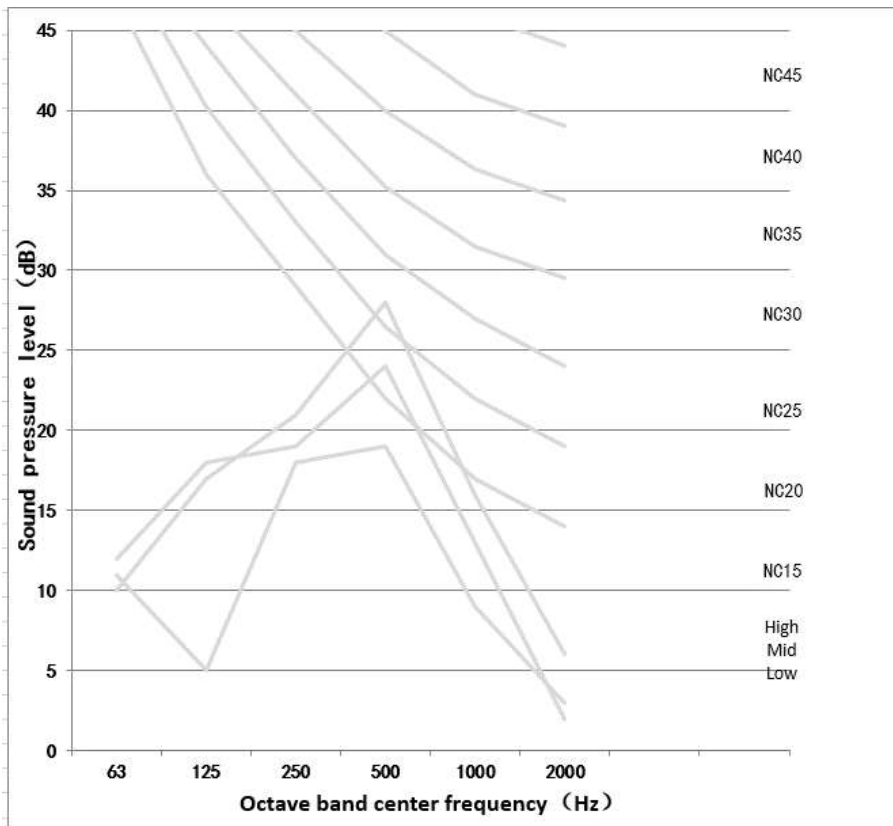

### 4. Ceiling Floor

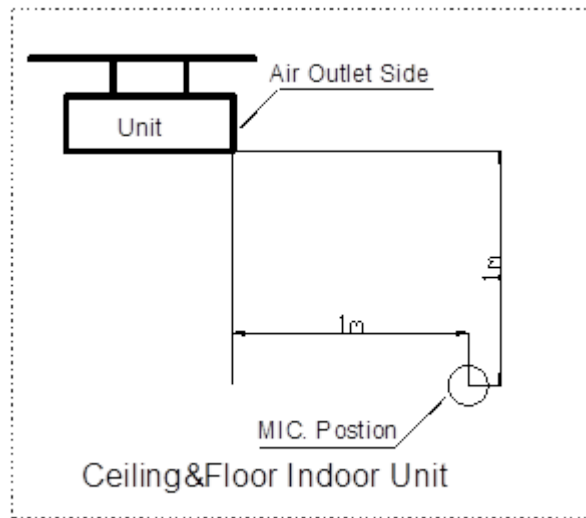

**Test site: 1m directly in front of the air outlet and 1m above the ground**

	Models	Noise level under three speeds of fan (dB(A))		
		H	M	L
<b>F Series</b>	AUCF-H18/4DR3HFA	40	35	33
	AUCF-H24/4DR3HFA	42	38	35
	AUCF-H36/NDR3HFC	50	46	41
	AUCF-H42/NDR3HFC	50	46	41
	AUCF-H48/SDR3HFC	50	46	41
	AUCF-H60/SDR3HFC	51	47	43

NC curves

AUCF-H18/4DR3HFA

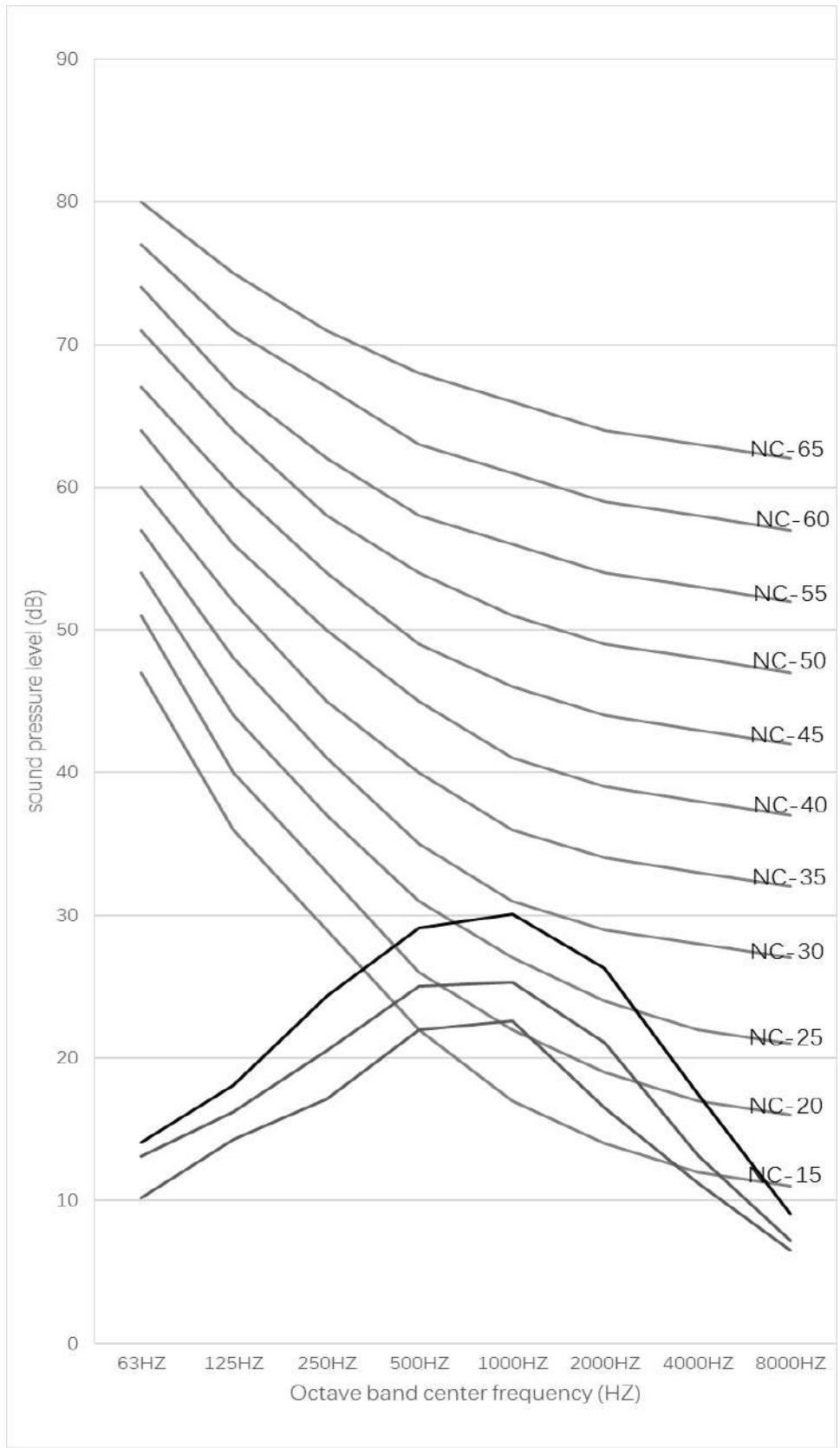

AUCF-H24/4DR3HFA

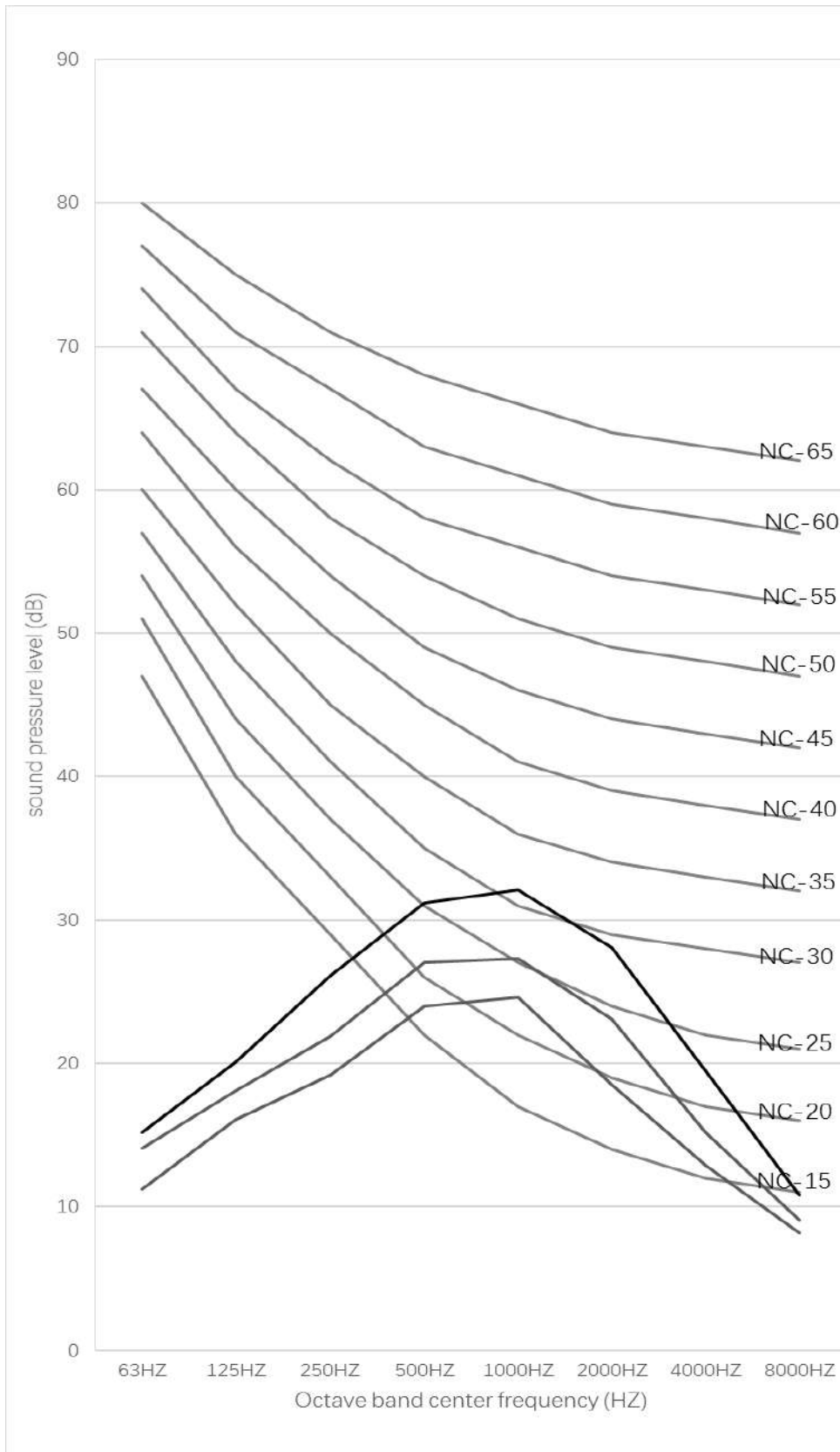

AUCF-H36/NDR3HFC, AUCF-H42/NDR3HFC

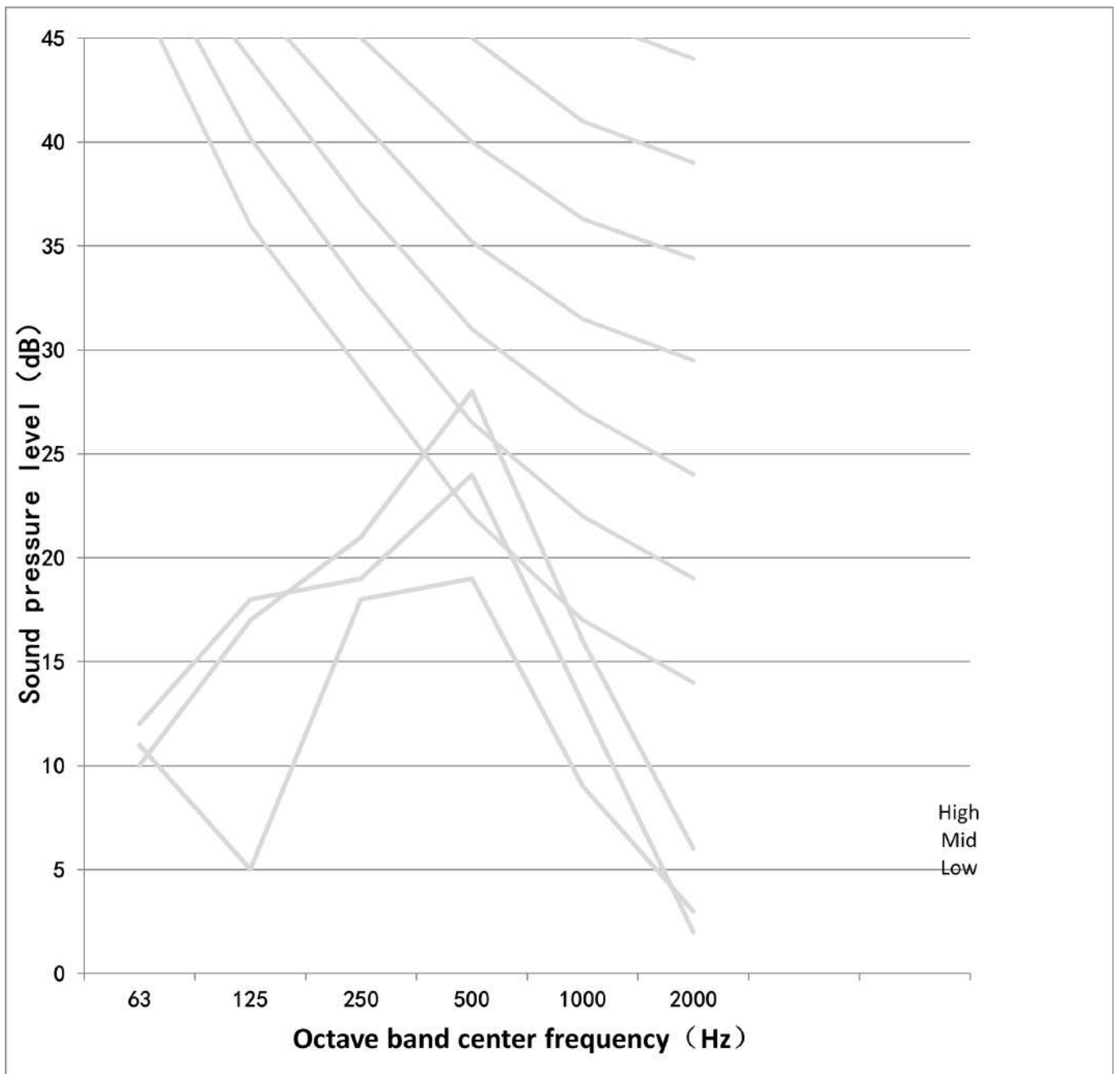

**AUCF-H48/SDR3HFC**

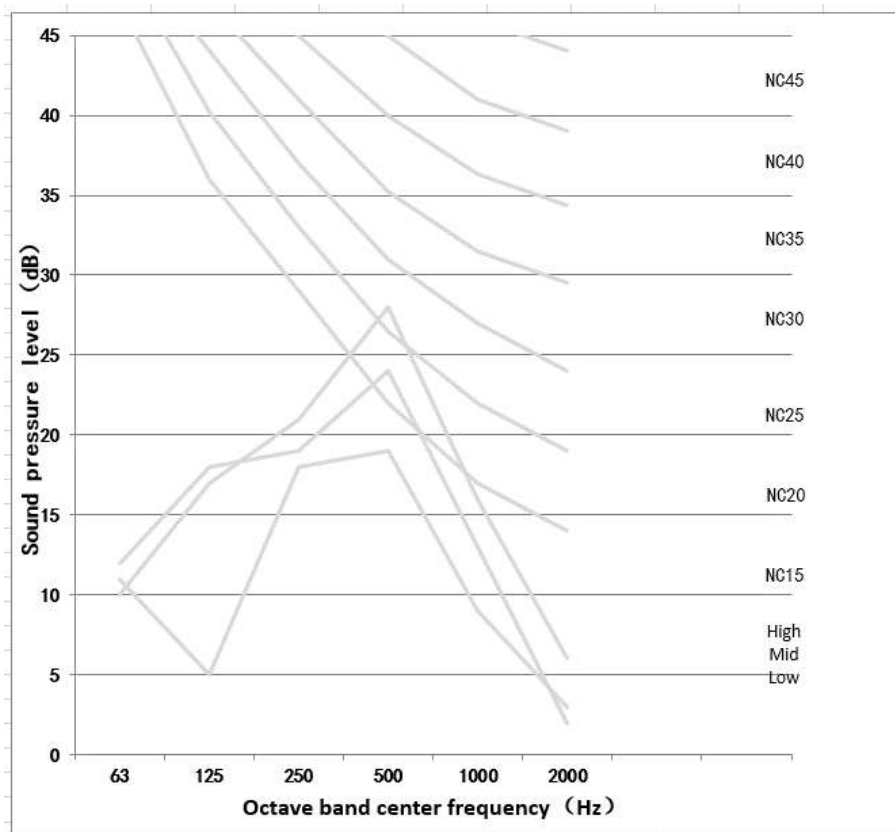

**AUCF-H60/SDR3HFC**

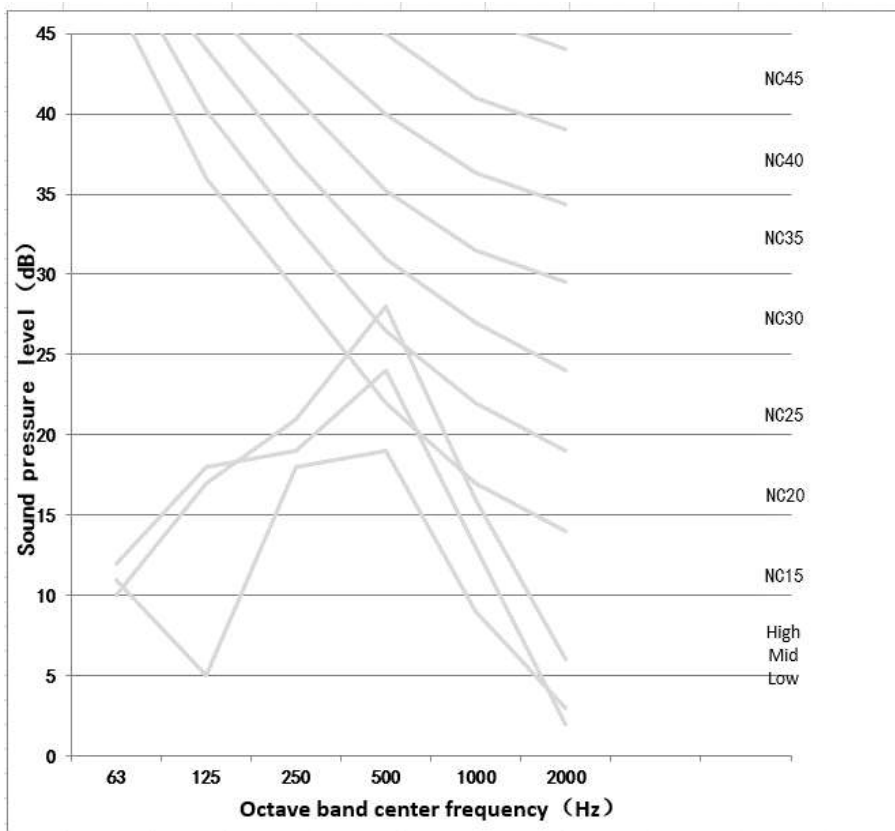

### 5. Console

Models	Noise level under three speeds of fan (dB(A))		
	H	M	L
AUCO-H12/4DR3HA	42	39	36
AUCO-H18/4DR3HA	44	40	37

#### NC curves

##### 1. AUCO-H12/4DR3HA

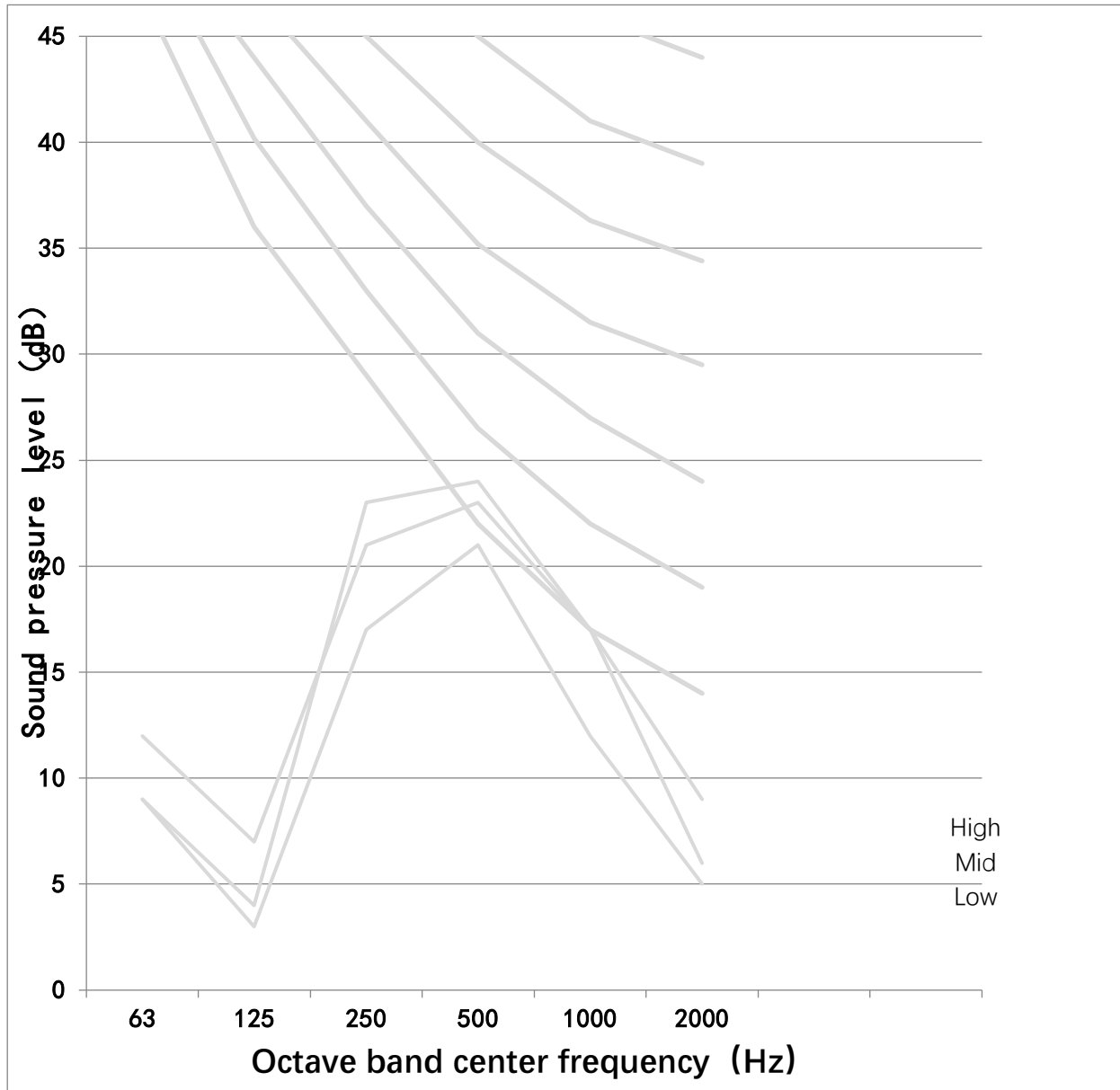



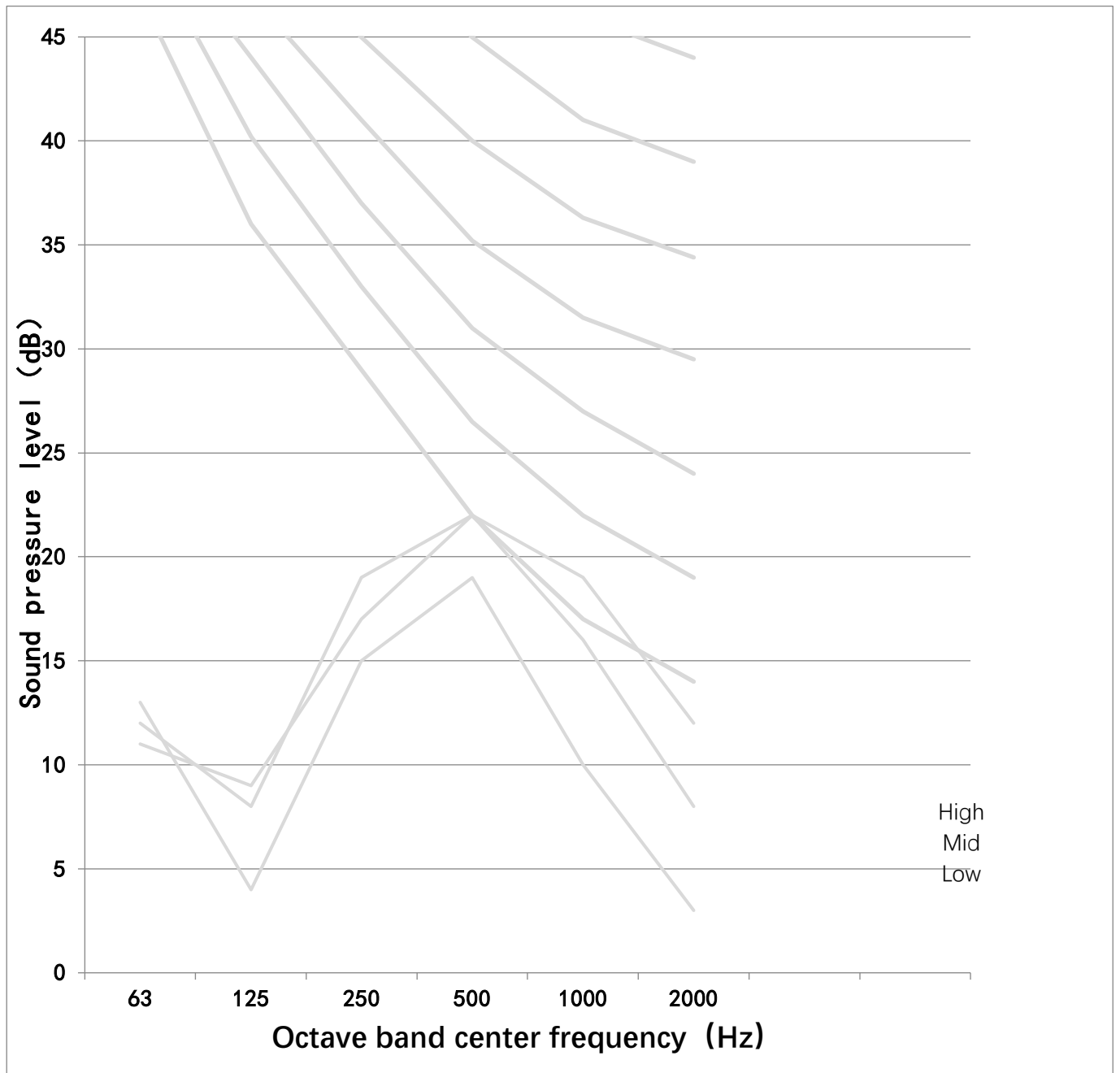















2. AUCO-H18/4DR3HA

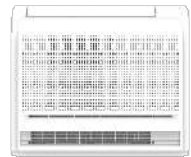

# Part9 Controller

## 1. Controller

Series		Standard	Optional		
Cassette					
		YK-H	YK-K	XK-05	XK-06
Duct					
		XK-05	YK-K	YK-H	XK-06
Ceiling floor					
		YK-H	YK-K	XK-05	XK-06
Console					
		YK-L	YK-K	XK-05	XK-06

Remote Controller YK-H

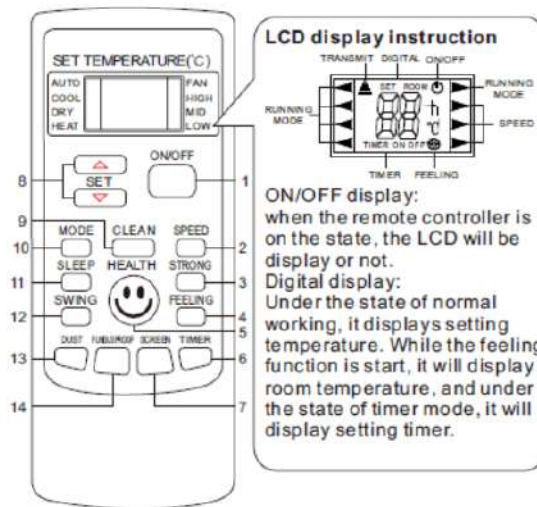

Remote Controller YK-K

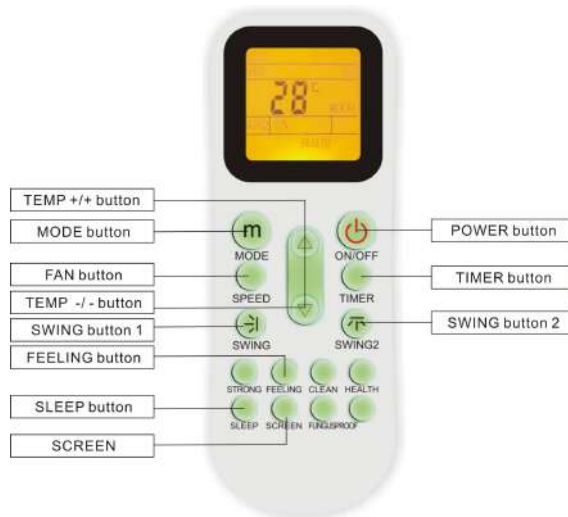

Remote Controller YK-L

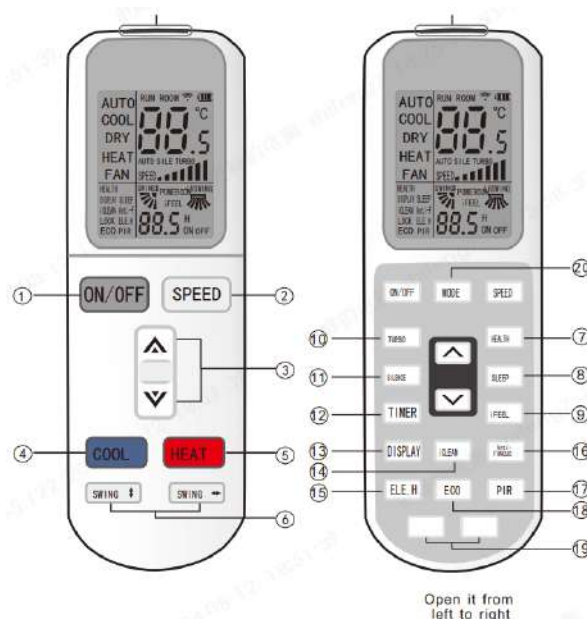

**Wired controller XK-05**

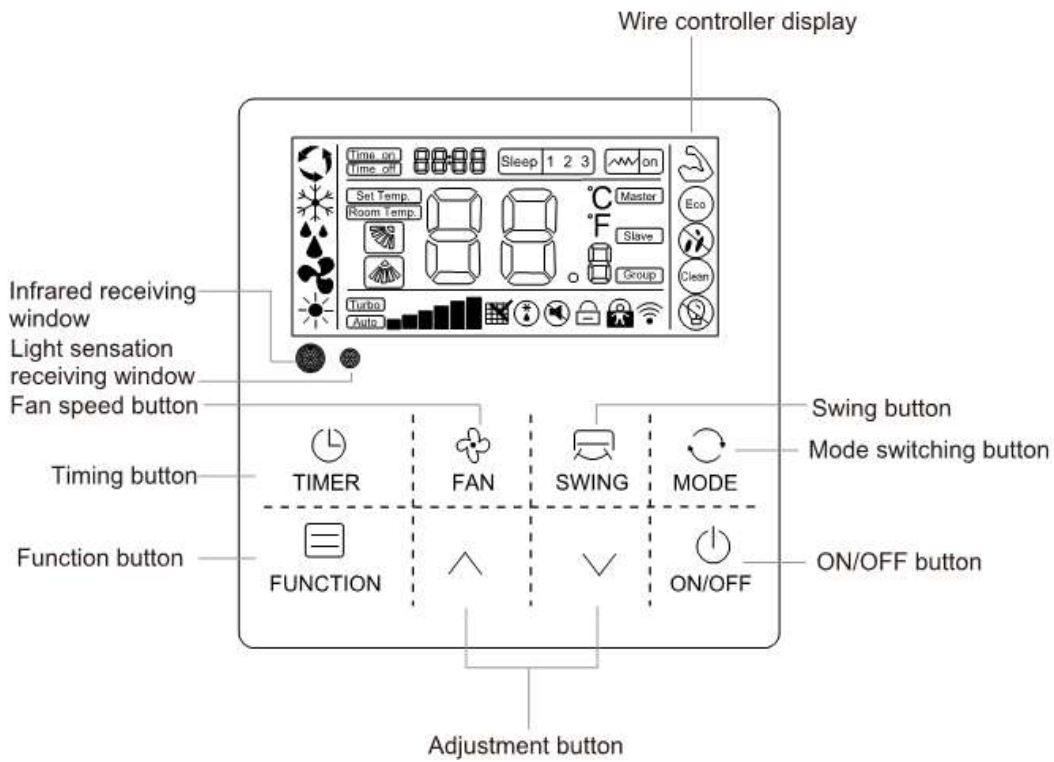

**Wired controller XK-06**

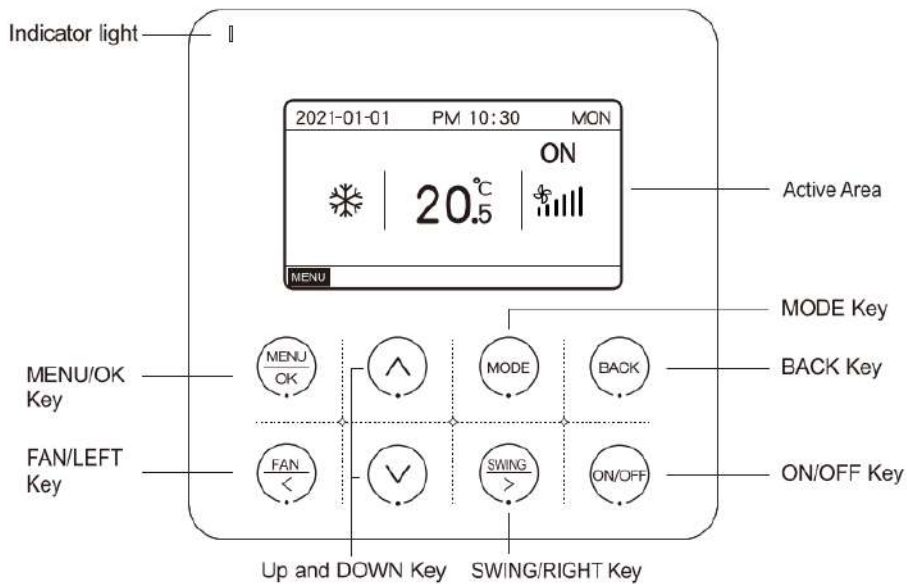

**Note:** For details of all the above controllers, please refer to the corresponding controller manual.

## 2. Connect the centralized controller

Light commercial products can be connected to the BMS or centralized controller through the mini gateway, as shown in the figure below:

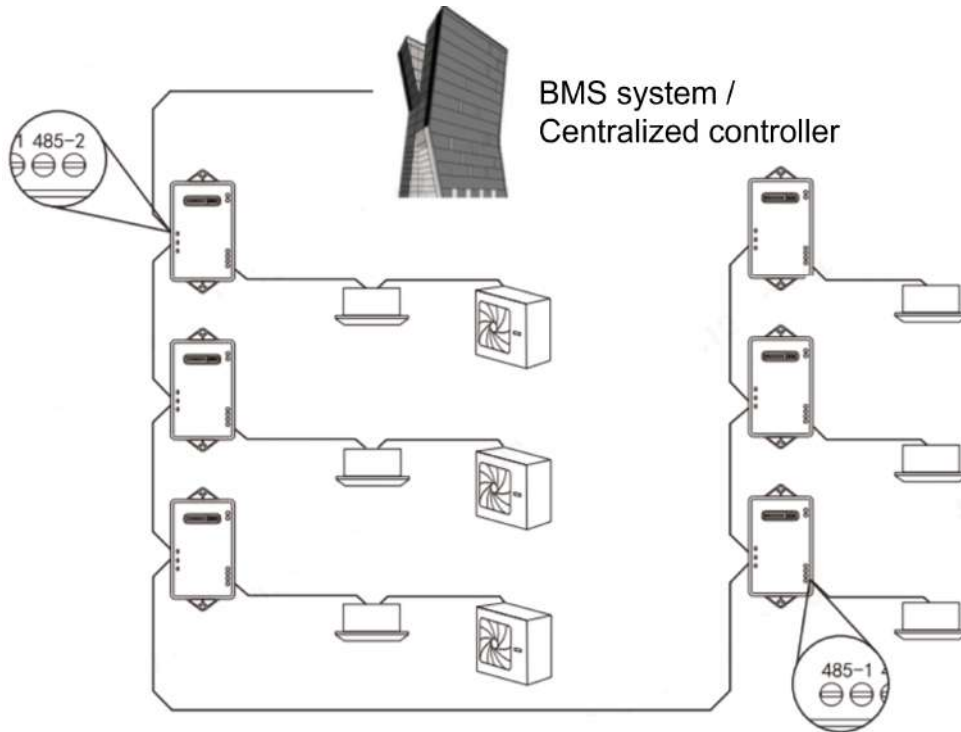

For light commercial products, although the ODU communicates with the IDU through the LNS, the IDU still has the RS485 port for communication between the IDU and the wired controller. The A and B terminals of the port can be connected to the MINI gateway for centralized control. As shown in the picture below:

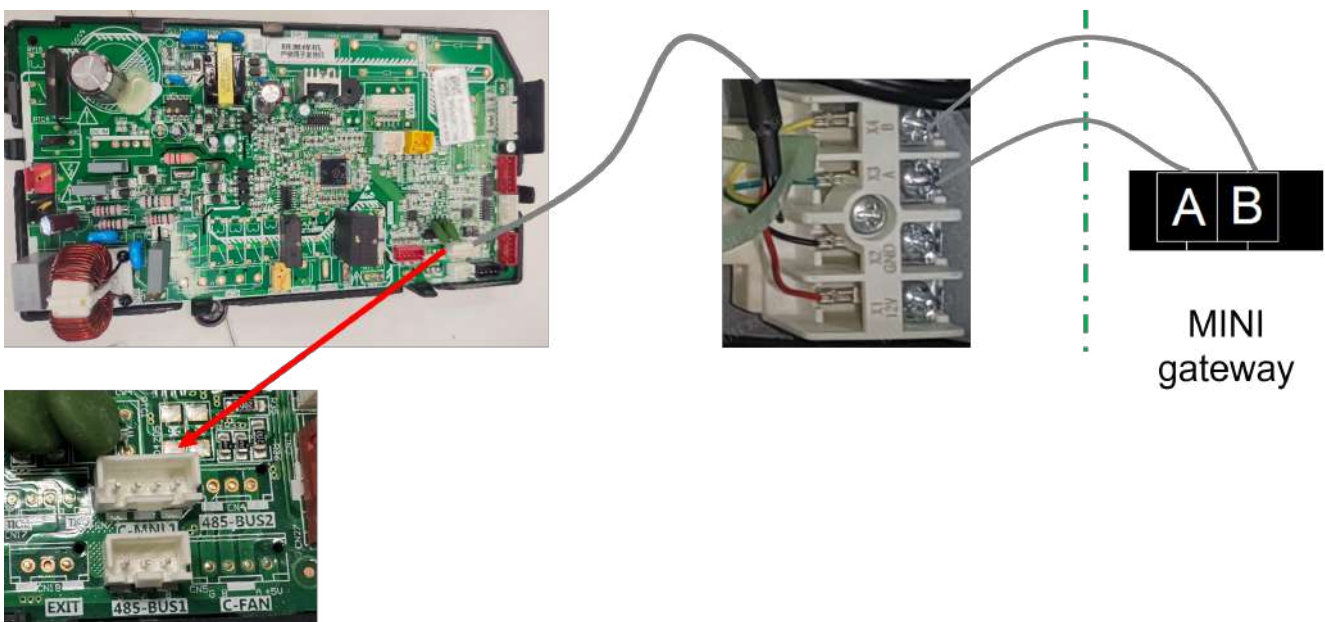

### 3. Parameters Setting

Indoor unit's parameters can be set by remote controller (YK-L) and wired controller—For after-sales (In indoor side, After the new PCB was replaced, indoor parameters set is necessary).

#### 3.1 Parameter Setting table (General parameter)

Model	【04】	【05】	【15】
	Model of IDU	Capacity of IDU	Selection of room sensor
AUMD-H12/NDR3HM2B	12	12	01
AUMD-H18/NDR3HM2B	12	18	01
AUMD-H24/NDR3HM2B	12	24	01
AUMD-H30/NDR3HC	12	30	01
AUMD-H36/NDR3HC	12	36	01
AUMD-H42/NDR3HC	12	42	01
AUMD-H48/SDR3HC	12	48	01
AUMD-H60/SDR3HC	12	60	01
AUCA-H12/4DR3HYAB	10	12	01
AUCA-H18/4DR3HYAB	37	18	01
AUCA-H24/4DR3HYAB	01	24	01
AUCA-H36/NDR3HYCB	01	36	01
AUCA-H42/NDR3HYCB	01	42	01
AUCA-H48/SDR3HYCB	01	48	01
AUCA-H60/SDR3HYCB	01	60	01
AUCF-H18/4DR3HFA	46	18	01
AUCF-H24/4DR3HFA	46	24	01
AUCF-H36/NDR3HFC	46	36	01
AUCF-H42/NDR3HFC	46	48	01
AUCF-H48/SDR3HFC	46	48	01
AUCF-H60/SDR3HFC	46	60	01

#### Note:

**【04】** : Model of IDU

**【05】** : Capacity of IDU

**【15】** : Selection of air return temperature sensor; 00 – sensor in indoor unit, 01—Sensor in wired controller

#### 3.2 Working mode parameter (Heating only function)

Under heating only mode, IDU cannot receive signal of other working mode besides “OFF” signal.

Once change the parameter, need to power on again to activate the function

Series No	Value	Meaning	Available mode
11	0	All mode	Cooling. Dehumidification. Fan. Heating. Auto
	1	No “Auto” mode	Cooling. Dehumidification. Fan. Heating
	2	Cooling	Cooling. Dehumidification. Fan
	3	Heating	Heating only

**Note:**

The duct type indoor unit produced before 2019.3 need to update program for IDU PCB so that achieve heating only.

**3.3 Parameter Setting by YK-L**

**Enter the setting interface**

- ① Make sure the remote controller is **off**
- ② Press the **two white button** at the down side simultaneously **more than 10s** to enter the address setting mode.

**Parameter Setting**

- ③ Press the [^] or [v] button to change the parameter series number
- ④ Press the [IClean] or [ECO] button to change the parameter correspondence
- ⑤ Press the [MODE] button to send order (Sent signal to display panels or receivers), Then can hearing buzzer once

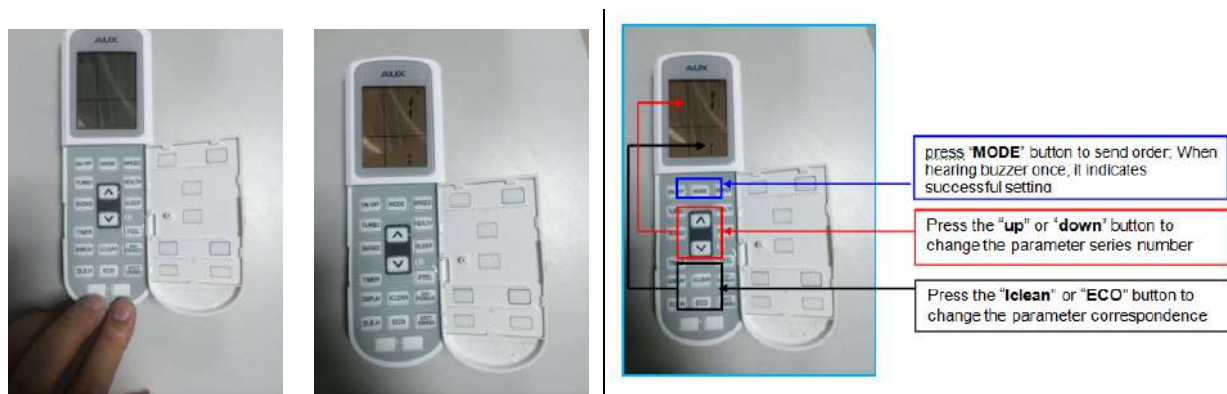

**For example:**

If you changed a new PCB to 18K cassette indoor unit , then you should set the type of the unit , check the above **【Parameter Setting Items table】** --- Mode of IDU is **【04】**, 18K cassette parameter is **【37】**

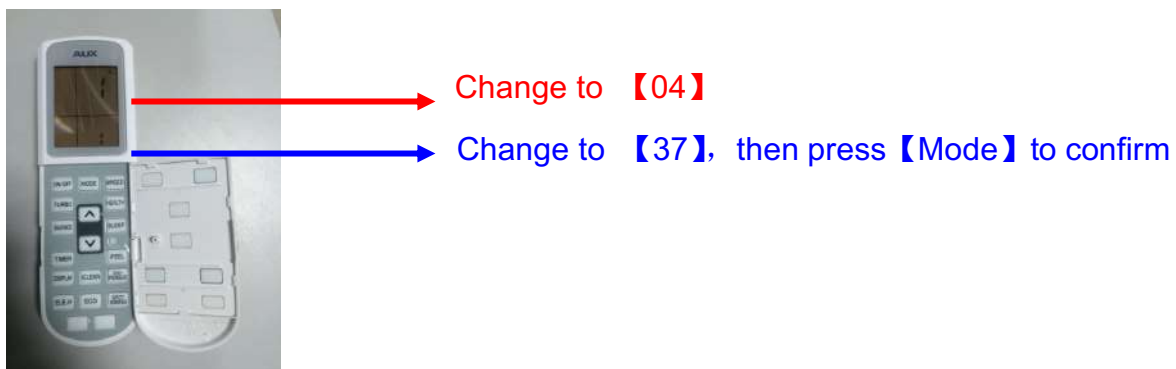

### 3.4 Parameter Setting by XK-04/ XK-05

#### Parameter checking

Press the “FUNCTION” button for 5 seconds, enter into the parameter checking interface.

The wired controller’s address will be displayed in the temperature zone of LED screen (press “FUNCTION” button, the wired controller’s address will flash, the wired controller’s

address can be changed through press the “^” or “v” , then press “FUNCTION” button to confirm);

In the timing setting zone: **HH** means series NO. **MM** means parameter value. After

Entering into IDU parameter checking , via pressing the “^” or “v” button ,you can check

the parameter value of series NO. **【04】 【05】 【1】** .

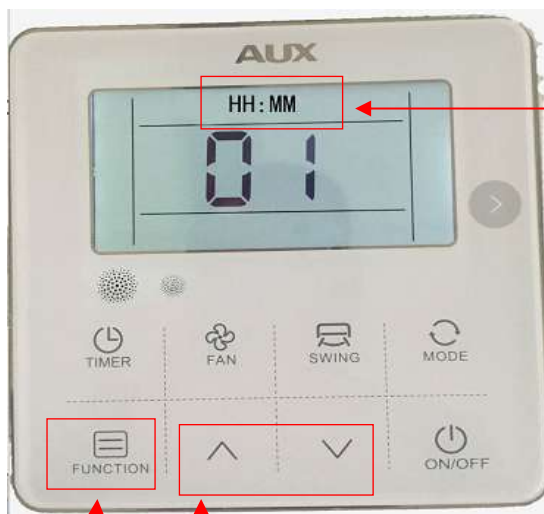

**HH:** means series NO.

**MM:** means parameter

1. Press “FUNCTION” for 5S, enter parameter checking model
2. Press “^” or “v” , change the parameter value of series

#### Parameter setting

**Only in parameter checking model**, press the “FUNCTION” button for 5 seconds, Enter into parameter setting model.

The corresponding parameter value “MM” begin to flash, changing it by pressing

The “^” or “v” button, after finished ,press the “FUNCTION” button to confirm. When finishing parameter setting, it will automatically go back to parameter checking model.



2. Press “ ”or“ ”, change the parameter value.

1. Only in checking model, Press “FUNCTION” for 5S, enter parameter checking model

**For example:**

If you want to change the PCB from cassette type to mid duct type for 42k unit , you should set the type of the unit , check the above **【Parameter Setting Items table】** --- Mode of IDU is **【04】**, 42K cassette parameter is **【11】** , 42K mid duct parameter is **【39】**

**【0411】 change to 【0439】 (step1)**





③ Press “FUNCTION” for 5S again, enter parameter setting model;

② Press the“ ”or“ ”button to get “04 11”

① Press “FUNCTION” for 5S,enter parameter check model;

**【0411】 change to 【0439】 (step2)**

- ④ Press the “ ” or “ ” button to get “**04 39**”  
 or 
- ⑤ After finishing setting , press “**FUNCTION**” to confirm

## 4. Room Card Function

### 4.1 Function setting

Parameter	Insert key card	Remove key card
0900	The original status is <b>OFF</b> . After the room card is inserted, the indoor unit starts in <b>AUTOMATIC MODE</b> , the wind speed is <b>AUTO</b> , and the indoor unit <b>CAN</b> receive commands from the controller for control.	The original state is <b>ON</b> . After the room card is removed, the indoor unit <b>URNS OFF</b> immediately and the indoor unit <b>CAN</b> receive commands from the controller for control.
0901	The indoor unit <b>CAN</b> receive commands from the controller for control.	The indoor unit <b>URNS OFF</b> immediately and the indoor unit <b>CANNOT</b> receive commands from the controller for control.
0902	The indoor unit <b>CAN</b> receive commands from the controller for control.	The original state is <b>ON</b> . After the room card is removed, the indoor unit <b>URNS OFF</b> immediately and the indoor unit <b>CAN</b> receive commands from the controller for control.
0903	The indoor unit <b>CAN</b> receive commands from the controller for control.	The original state is <b>ON</b> . After the room card is removed: if the current mode is non-heating or non-AUTO, it will be turned into <b>FAN MODE</b> and low wind speed operation. Otherwise, the IDU <b>URNS OFF</b> ; In this state, the indoor unit <b>CAN</b> receive commands from the controller for control.

※ How to set the room card function ( Set method same as the above 【Part 9 →2.2Parameter Setting by YK-L or 2.3 Parameter Setting by XK-04/XK-05 】

For example (XK-05)

Step 1

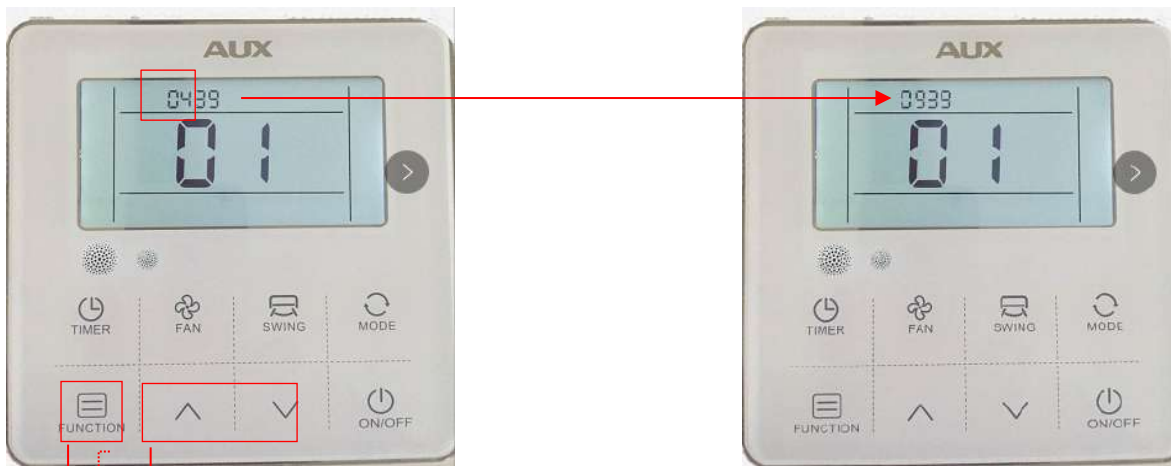

- ③ Press “FUNCTION” for 5S again, enter parameter setting model;
- ② Press the “ ” or “ ” button to get “09 39”
- ① Press “FUNCTION” for 5S, enter parameter check model;

Step 2

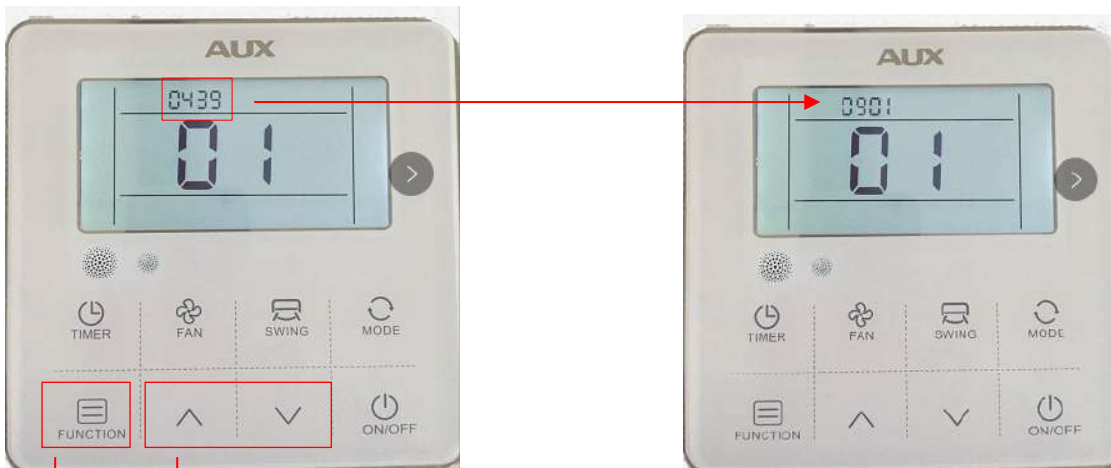

- ④ Press the “ ” or “ ” button to get “09 01”
- ⑤ after finishing setting , press “FUNCTION” to confirm

4.2 Wiring diagram

When the room card is inserted, the air conditioning can be controlled; when you leave the room, the AC will standby, can't be controlled.

**【DUCT TYPE】**

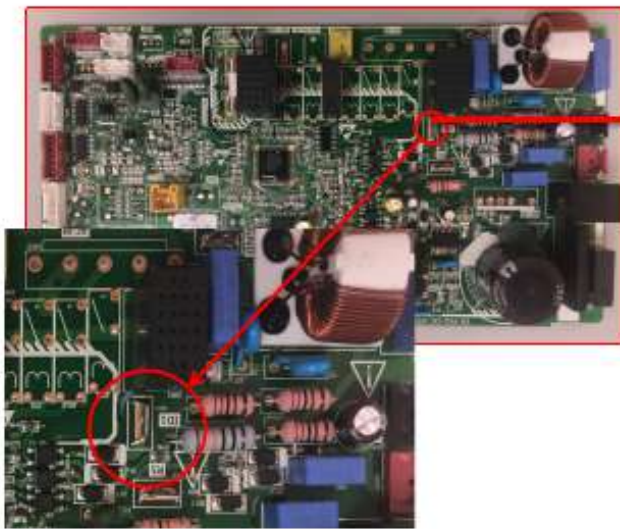

To power 220V

Room Card

**【Cassette】 and 【ceiling& floor】**



To power 220V

Room Card



## 5. WIFI Module

### 5.1 WIFI Module Configuration

#### ① APP Download

Mobile terminal scans the following dimensional code to download APP, or search “AC Freedom” in APPSTORE and Google store



#### ② Light Commercial WIFI Module Installation

Connect the WIFI module communication wire to WIFI interfaces of main PCB, as shown below:

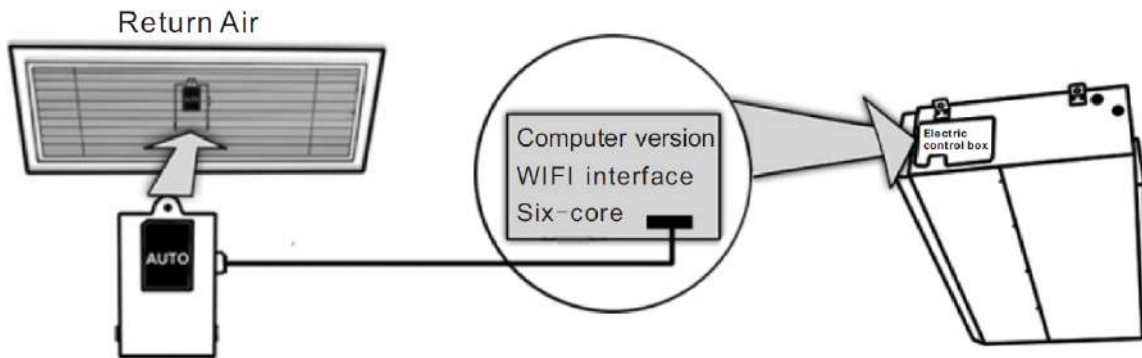

The WIFI module should be placed in the return air or some other place in WIFI area. (customers buy the wireless router)

#### ③ APP Configuration

- Press "healthy" button 8 times consecutive, and buzzer even ring two sound then into the configuration
- Connect mobile terminals to WIFI, open APP “AC Freedom”, and then operate following the steps below:

Click "Add device"

Wi-Fi name will automatically appear, enter password to start configuration (first configuration takes about 1 minute).

After finishing configuration, on screen bottom will indicate "Finish", then it will automatically return to "Device list" interface and shows the configured AC.

#### Note:

If the configuration fails or you change the password of wireless router, you need to reset the WIFI module to reconnect: Turn on the power of the module, then repeat the steps above for APP configuration.

## 5.2 AC management

### ① Modify AC name and locking function

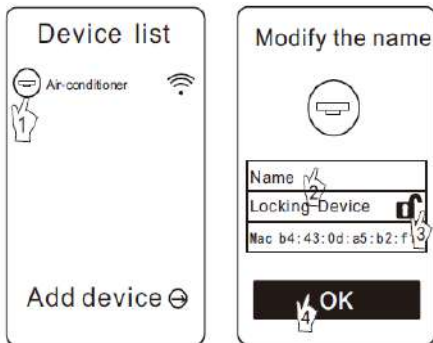

**Note:**

If you had locked AC equipment, you need to unlock before connecting other mobile terminal. If the mobile terminal locked AC was accidentally lost, you need to reset WIFI module first, and then use the new mobile terminal to connect (Reset step is same with 1.3 APP configuration).

② For other instructions, please refer to "HELP" in APP.

### ③ Remote-control device

Connect the wireless router to internet, then open the GPRS. It means the remote control device, voice control function only effective after connected to the Internet

## 5.3 Trouble Shooting

### If unable to properly configured or connect the WIFI box:

- Make sure the WIFI box for wiring is properly connected.
- Long press WIFI box 8 seconds to reconfigure the positive button. If the problem can't be solved, please contact after sales person.

## 5.4 Technical Parameters

- Working temperature: 0~50℃;
- Working environment humidity: 20~90%RH;
- Dimensions: 78 X 52 X 15.5
- Configuration cable wire length: 1500mm

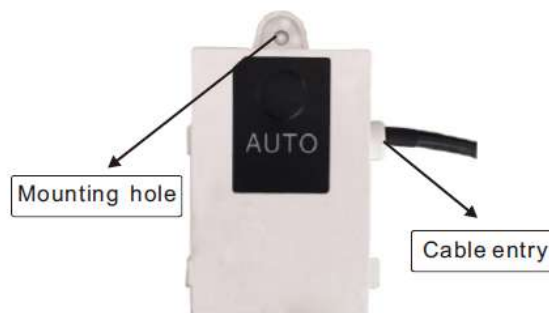

## 6. Static Pressure setting

### 6.1 Factory default

Capacity	Model	Default (Pa)	Parameters
12k/Btu	AUMD-H12/NDR3HM2B	25	0602
18k/Btu	AUMD-H18/NDR3HM2B	25	0602
24k/Btu	AUMD-H24/NDR3HM2B,	25	0602
30k/Btu	AUMD-H30/NDR3HC	37	0604
36k/Btu	AUMD-H36/NDR3HC	37	0604
36k/Btu	AUMD-H42/NDR3HC	37	0604
48k/Btu	AUMD-H48/SDR3HC	50	0605
60k/Btu	AUMD-H60/SDR3HC	50	0605

### 6.2 Static Pressure setting (30Pa-example) use XK-05

**【Step 1】** Feel free to touch a button and light up the screen, As shown in the right picture



**【Step 2】** Press the "FUNCTION" button for 5s to enter the set interface, As shown in the following picture



**【Step 3】** Press “ $\Delta \nabla$ ” button changing the first 2 numbers of “01XX” to “06XX”, As shown in the following picture

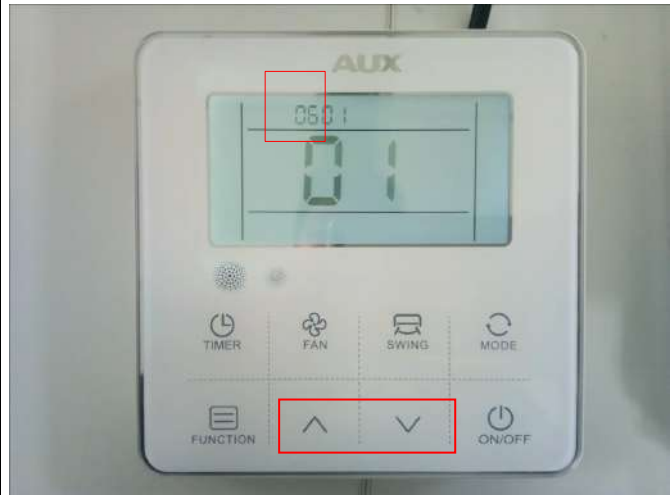

**【Step 4】** Press the “FUNCTION” button for 5S again to enter ESP set interface, the last 2 numbers of “0601” will be Twinkle ,then Press “ $\Delta \nabla$ ” button changing the last 2 numbers of “06XX” to set the ESP of IDU,As shown in the following picture,The “0603” means that ESP of IDU is **30 Pa**.



**ESP setting table**

ESP(Pa)	0	10	20	30	40	50	60	70	80
parameter values	0600	0601	0602	0603	0604	0605	0606	0607	0608
ESP(Pa)	90	100	110	120	130	140	150	160	
parameter values	0609	0610	0611	0612	0613	0614	0615	0616	

**【Step 5】** Press “FUNCTION” button to confirm,  
As shown in the picture



**【Step 6】** Press “Δ” button changing the first 2 numbers of “06XX” to “07XX”, As shown in the picture



**【Step 7】** Press the “FUNCTION” button for 5S again , the last 2 numbers of “07XX” will be Twinkle ,then Press “Δ ▽”button change “07XX” to “0701” Confirm the ESP of IDU,As shown in the picture,

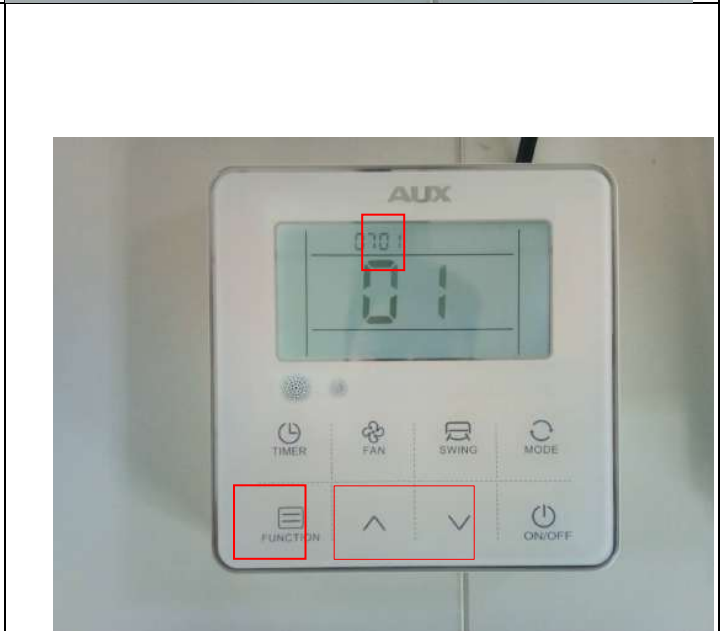

【 Step 8 】 Press “**FUNCTION**” button to confirm, finishing set ,As shown in the picture.



※ Use Remote controller(YK-L) and XK-04 Set method same as the above XK-05

# Part10 PCB Instruction

## 1. Outdoor Unit PCB

### 1.1 AL-H12/NDR3HB2(U)

#### Main PCB

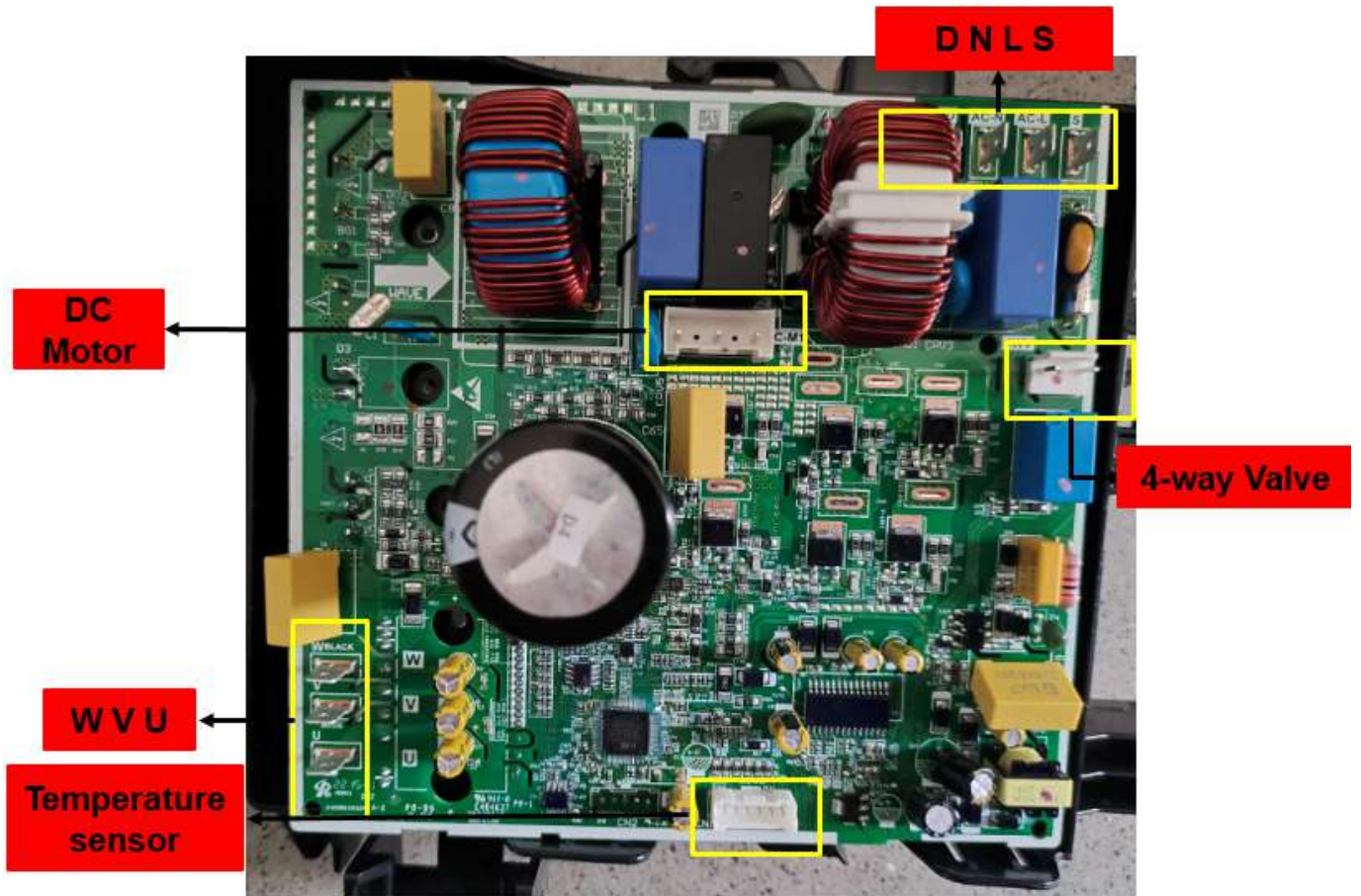

1.2 AL-H18/NDR3HB2(U), AL-H24NDR3HB2(U), AL-H30/NDR3HB2(U)

Main PCB

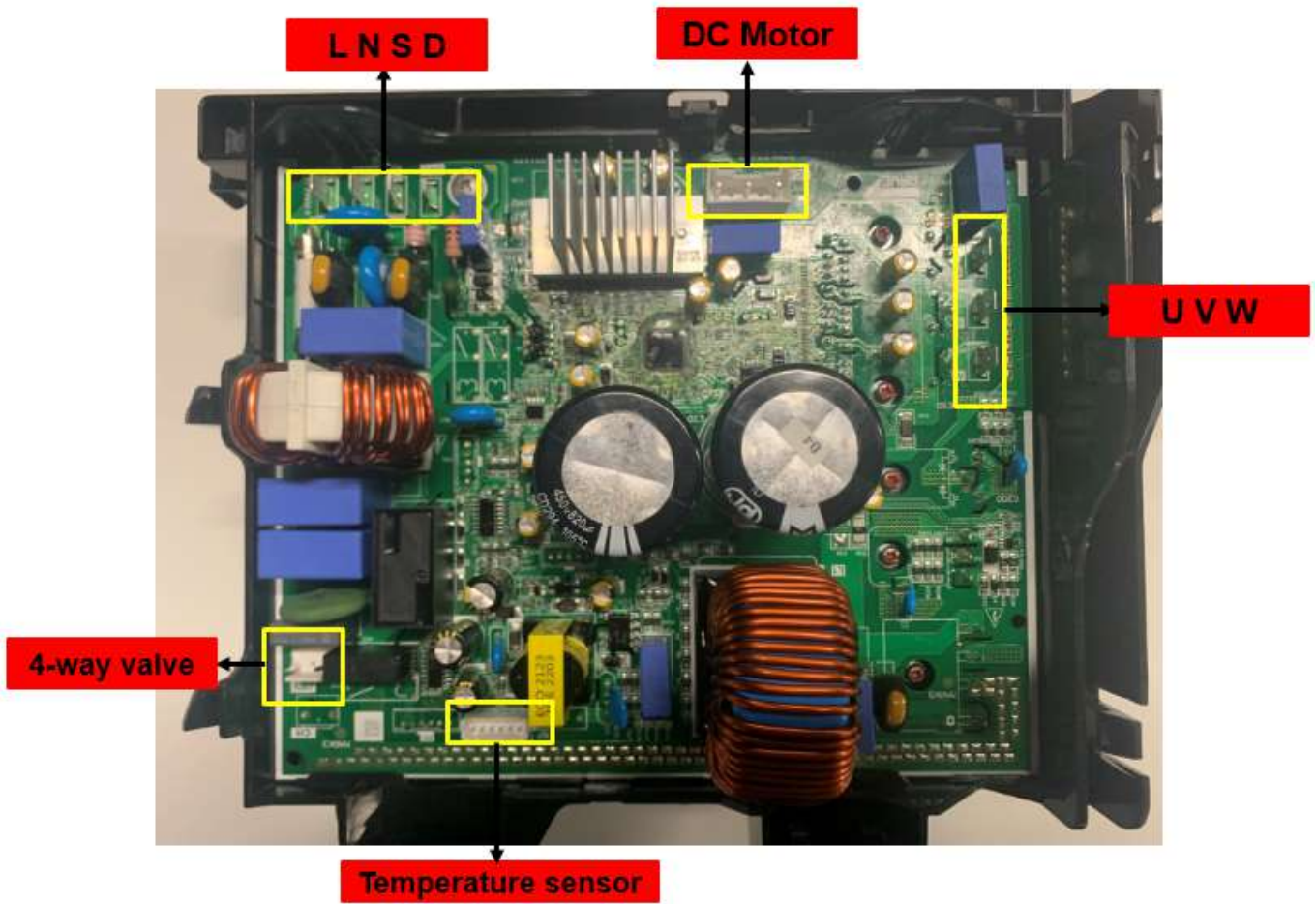

1.3 AL-H42/NDR3C2(U), AL-H42/NDR3C2(U)

PCB

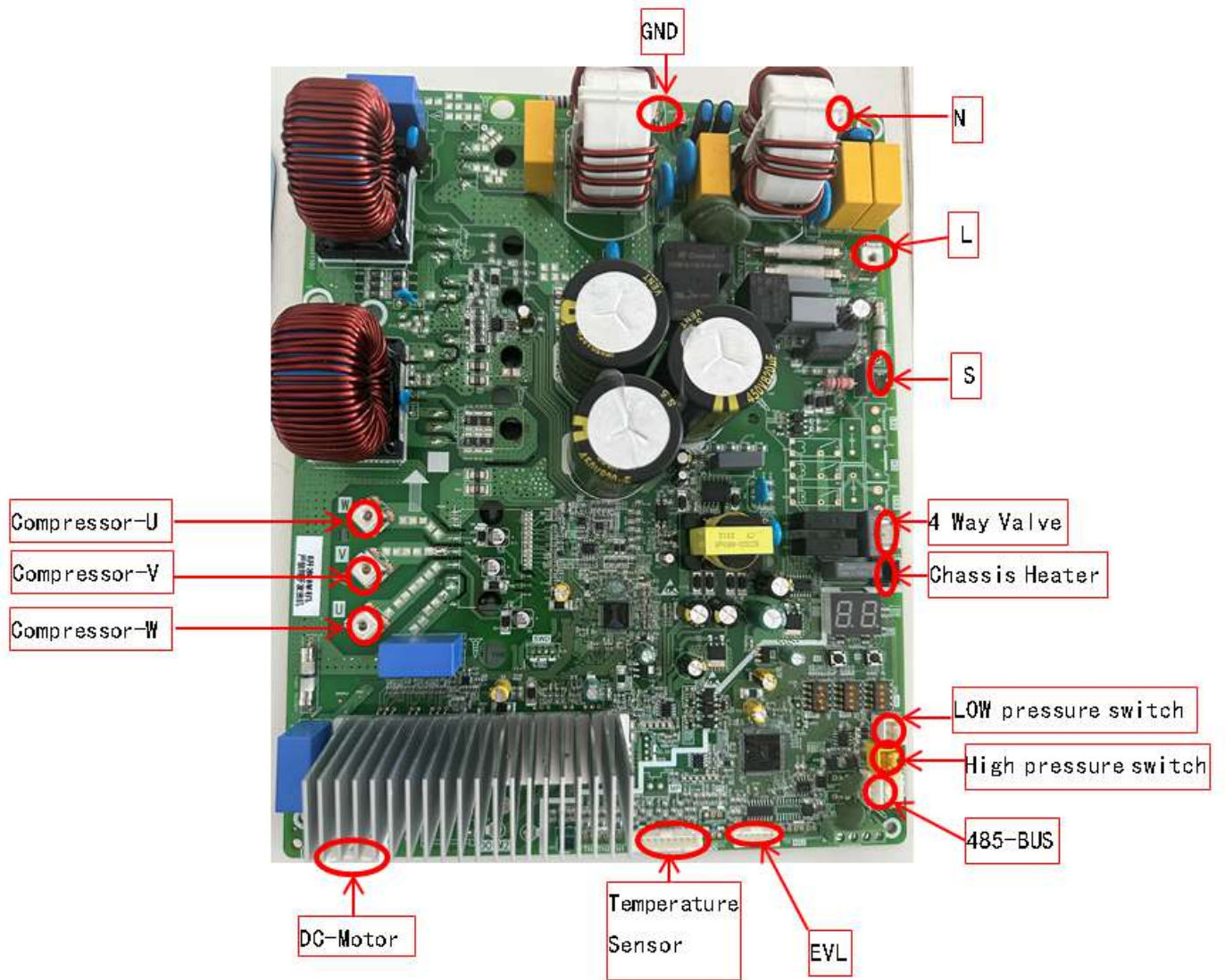

1.4 AL-H48/SDR3C2(U), AL-H60/SDR3C2(U)

PCB

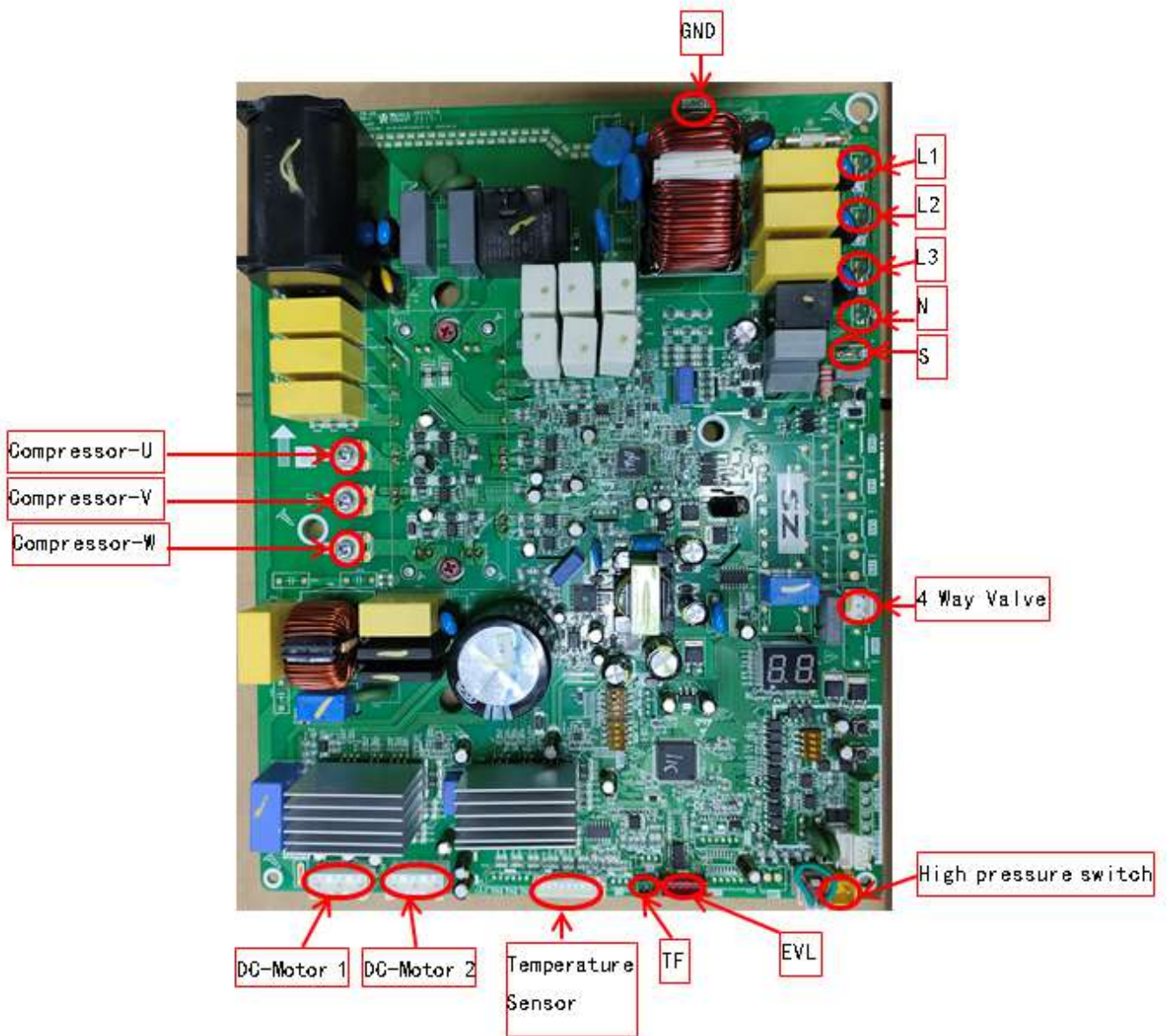

## 2. Indoor Unit PCB

### 2.1.Cassette

AUCA-H12/4DR3HYAB, AUCA-H18/4DR3HYAB, AUCA-H24/4DR3HYAB

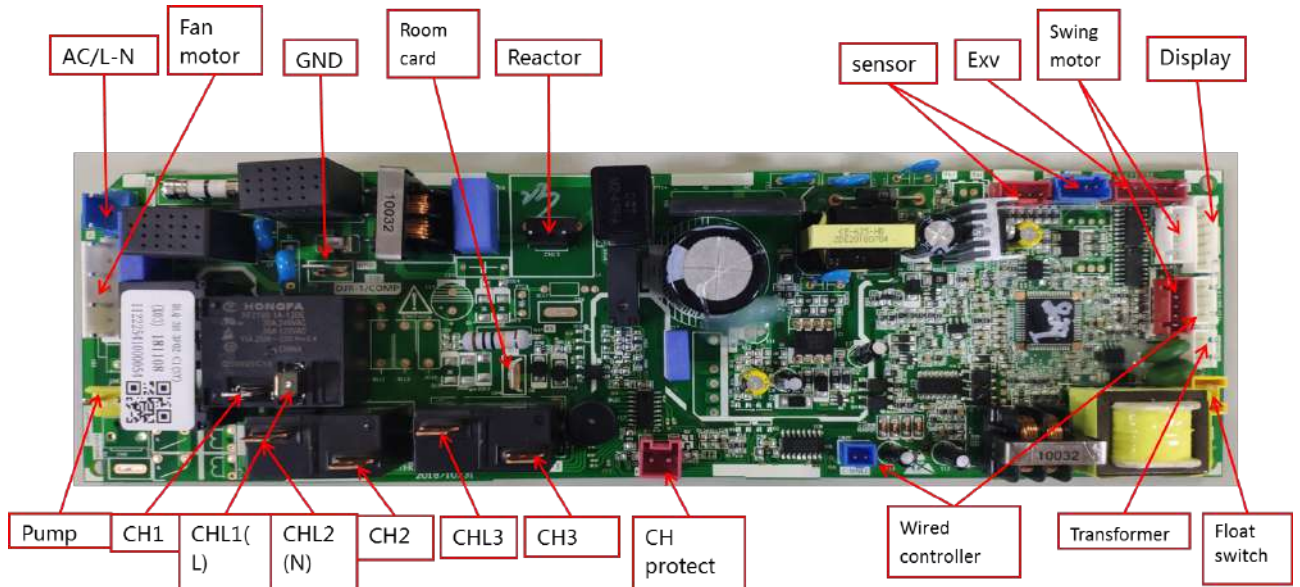

AUCA-H36/NDR3HYCB, AUCA-H42/NDR3HYCB, AUCA-H48/SDR3HYCB, AUCA-H60/SDR3HYCB

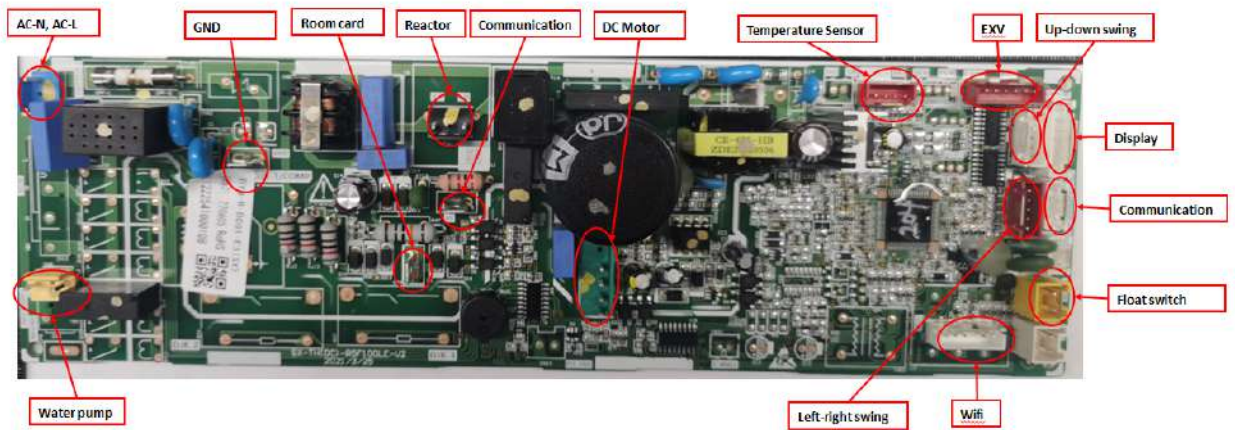

2.2.Ceiling & Floor

AUCF-H18/4DR3HFA,AUCF-H24/4DR3HFA

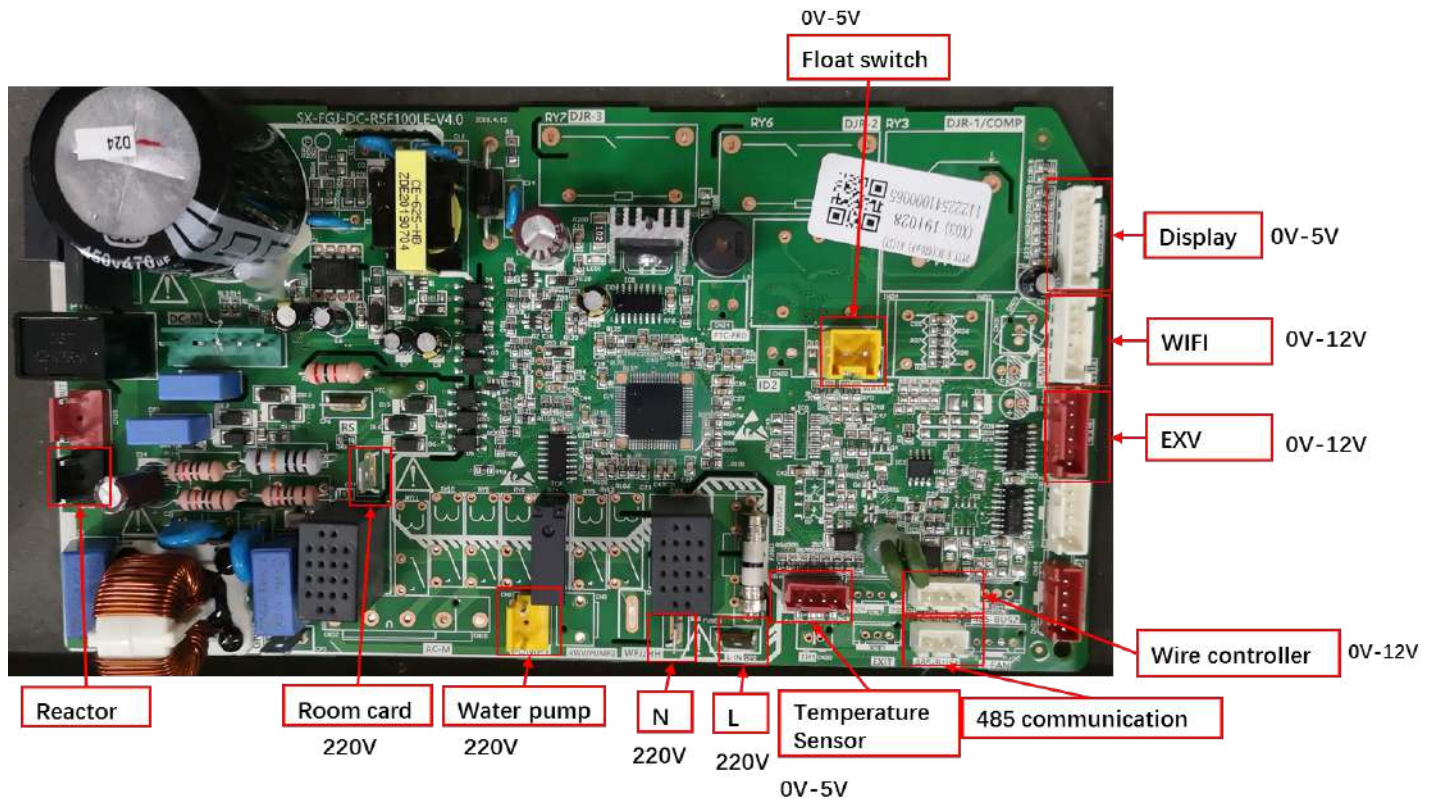

AUCF-H36/NDR3HFC, AUCF-H42/NDR3HFC

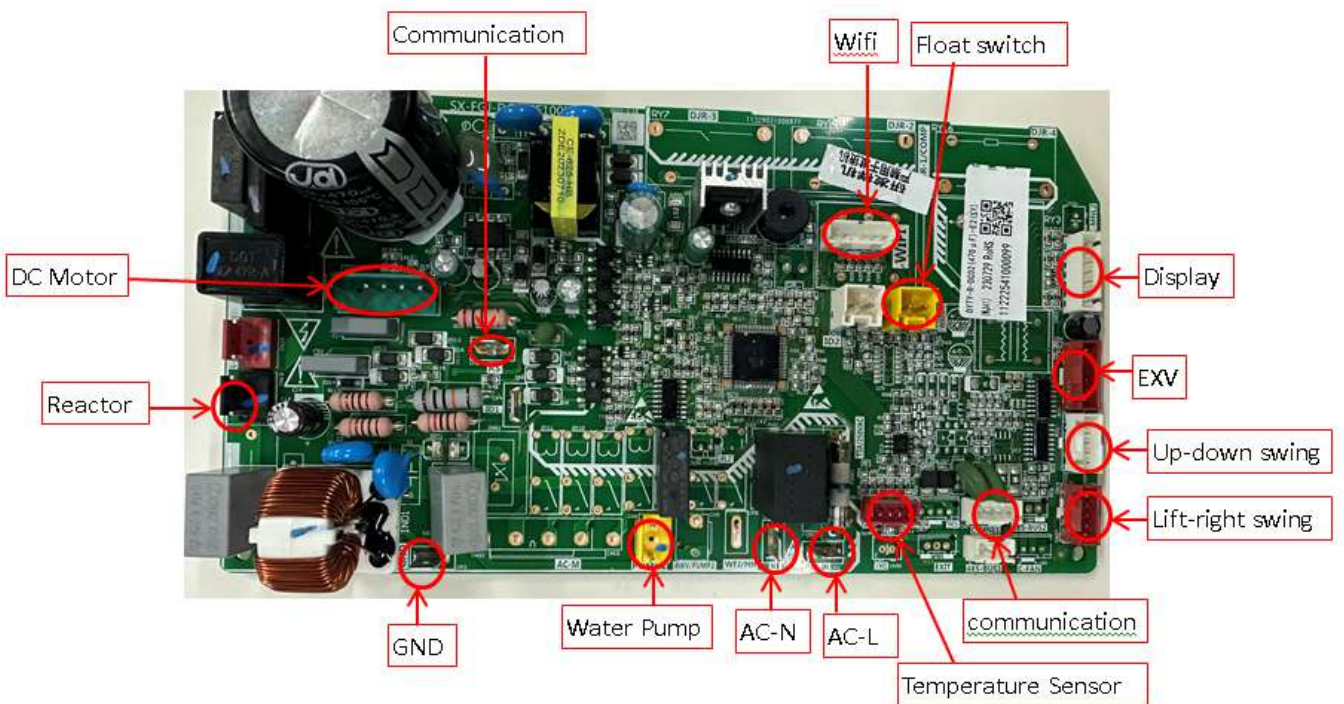

AUCF-H48/SDR3HFC, AUCF-H60/SDR3HFC

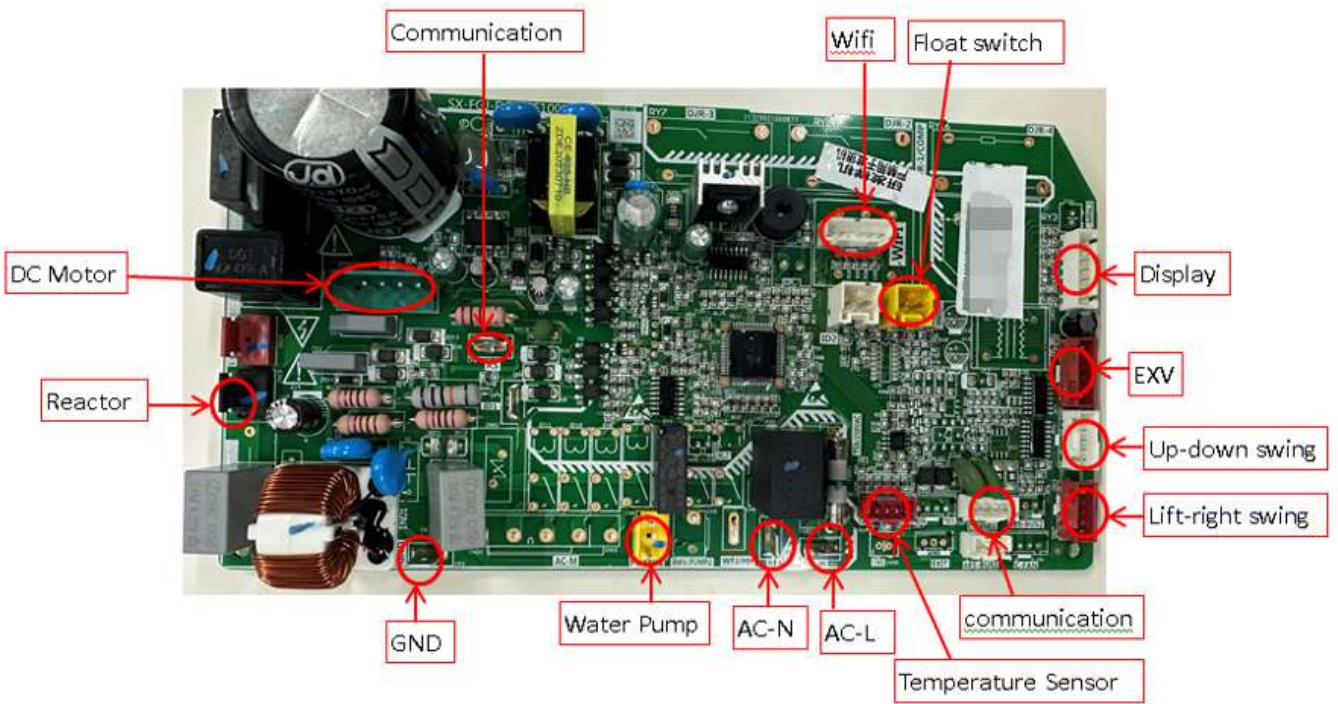

2.3 Duct

AUMD-H12/NDR3HM2B、AUMD-H18/NDR3HM2B

Main PCB

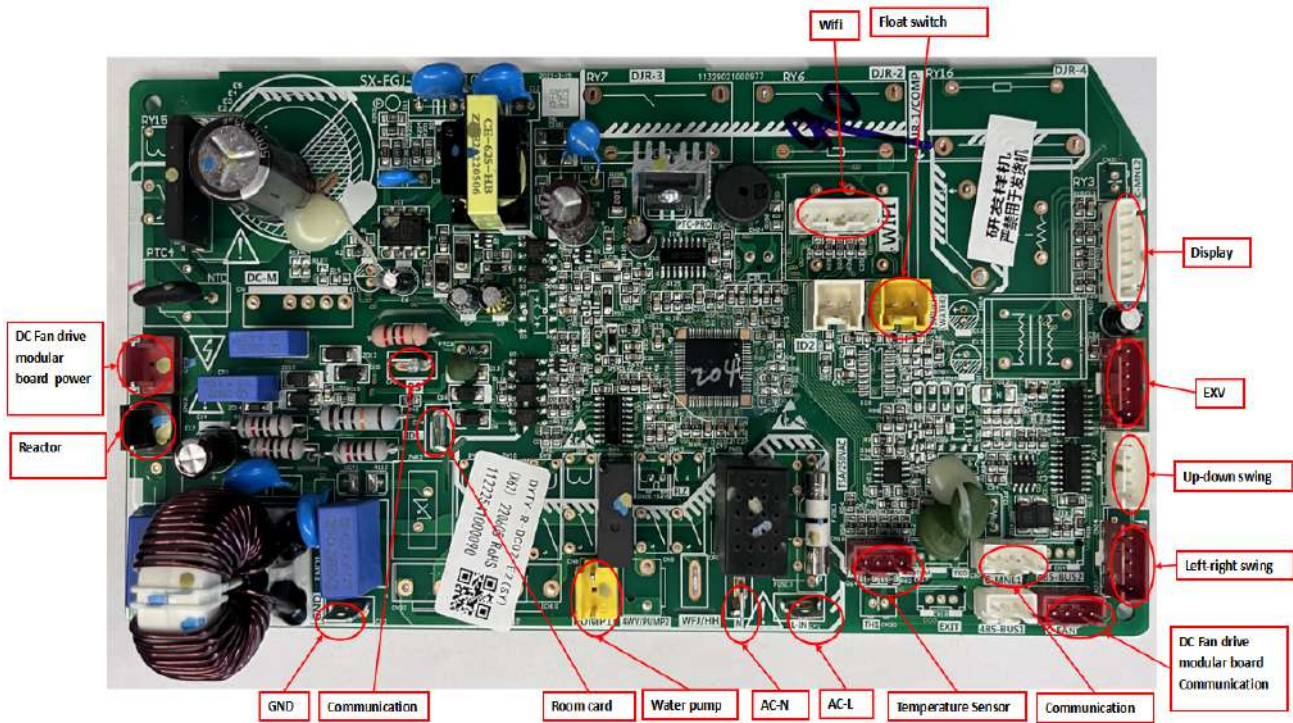

AUMD-H24/NDR3HM2B, AUMD-H30/NDR3HC

Main PCB

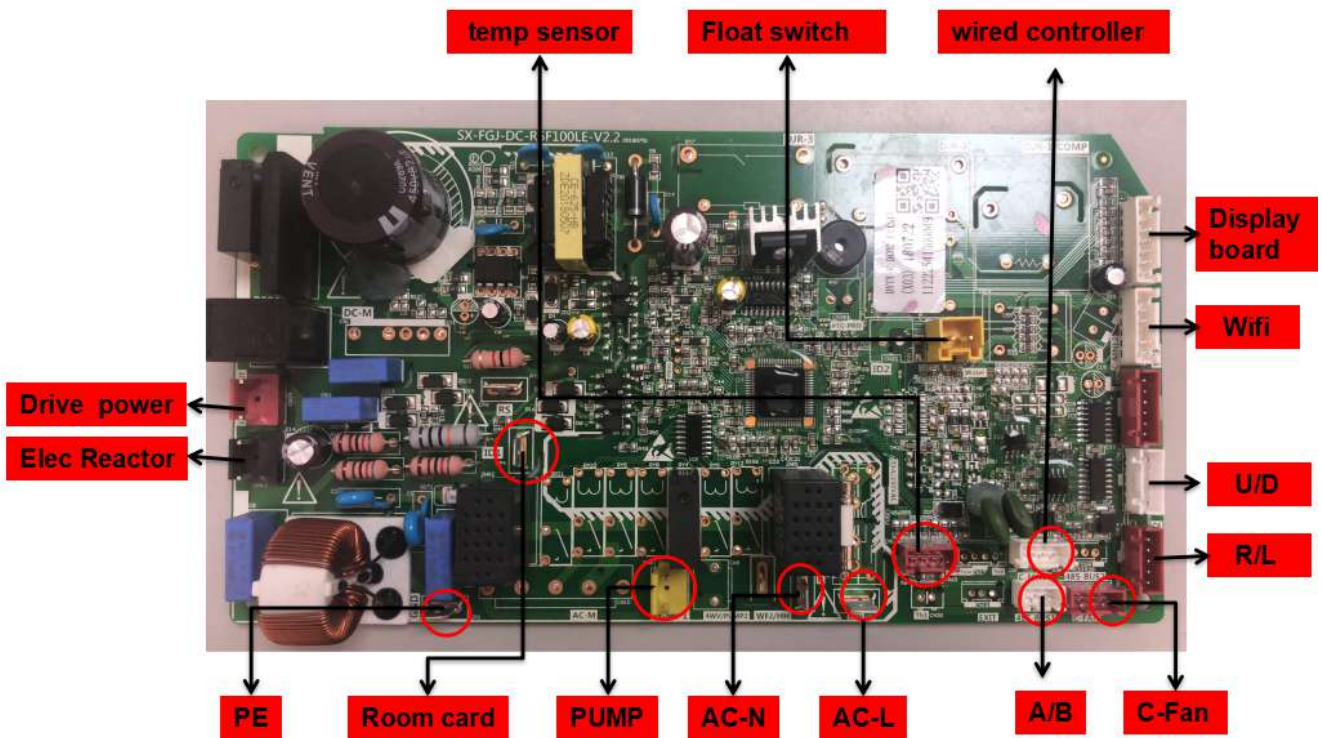

**AUMD-H36/NDR3HC, AUMD-H42/NDR3HC, AUMD-H48/SDR3HC, AUMD-H60/SDR3HC**

**Main PCB**

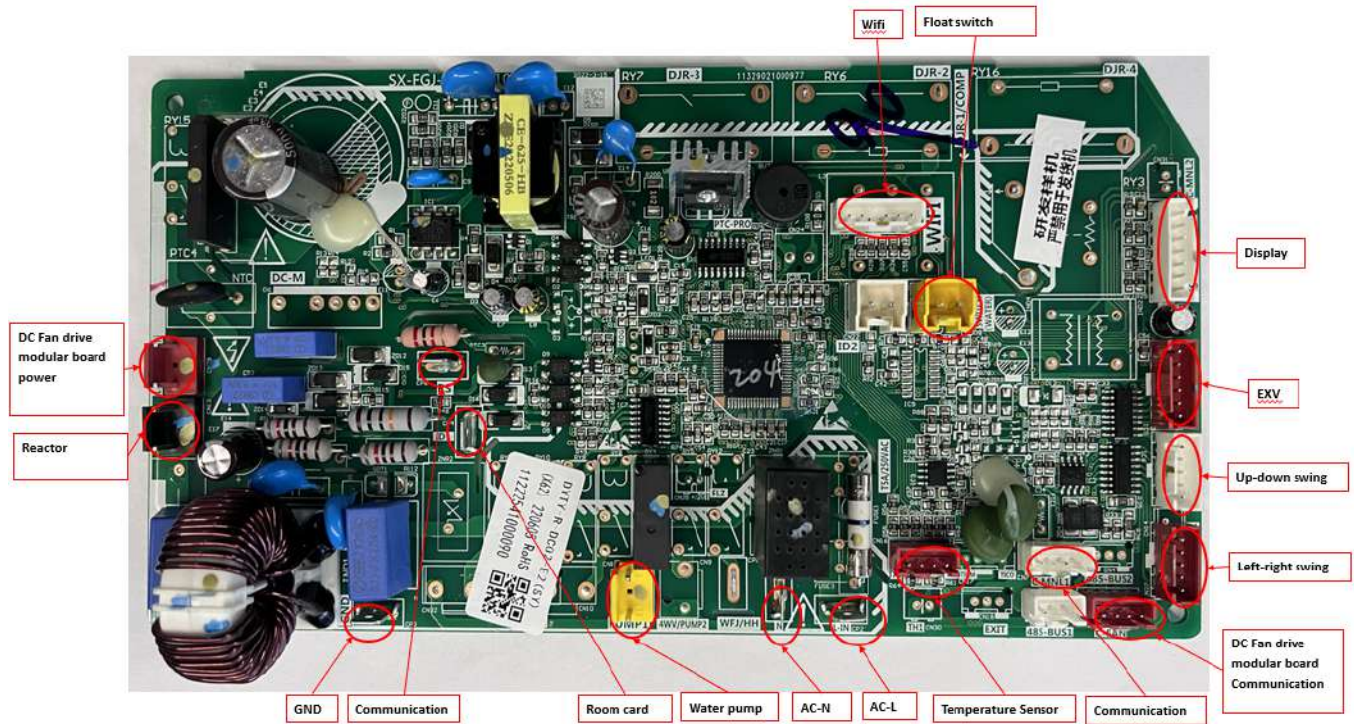

**Driver Modular**

**12-18K: 1122254300084 CJ Driver modular QD-12121F160W DC fan motor -2(SY)**

**24-60K: 1122254300072 CJ Driver modular QD-12121F560W DC fan motor -1(SY)**

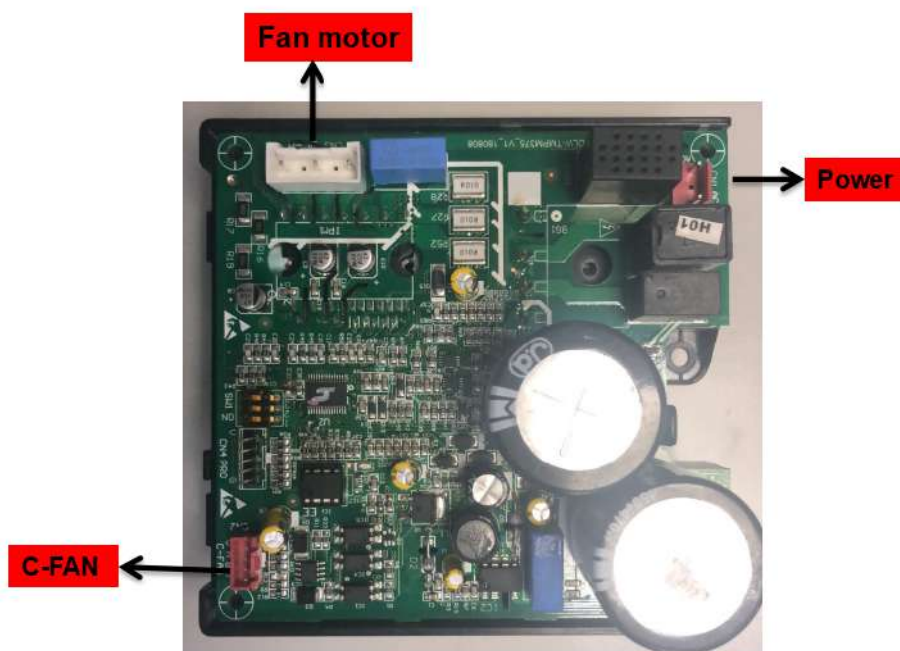

2.4 Console

AUCO-H12/4DR3HA、AUCO-H18/4DR3HA

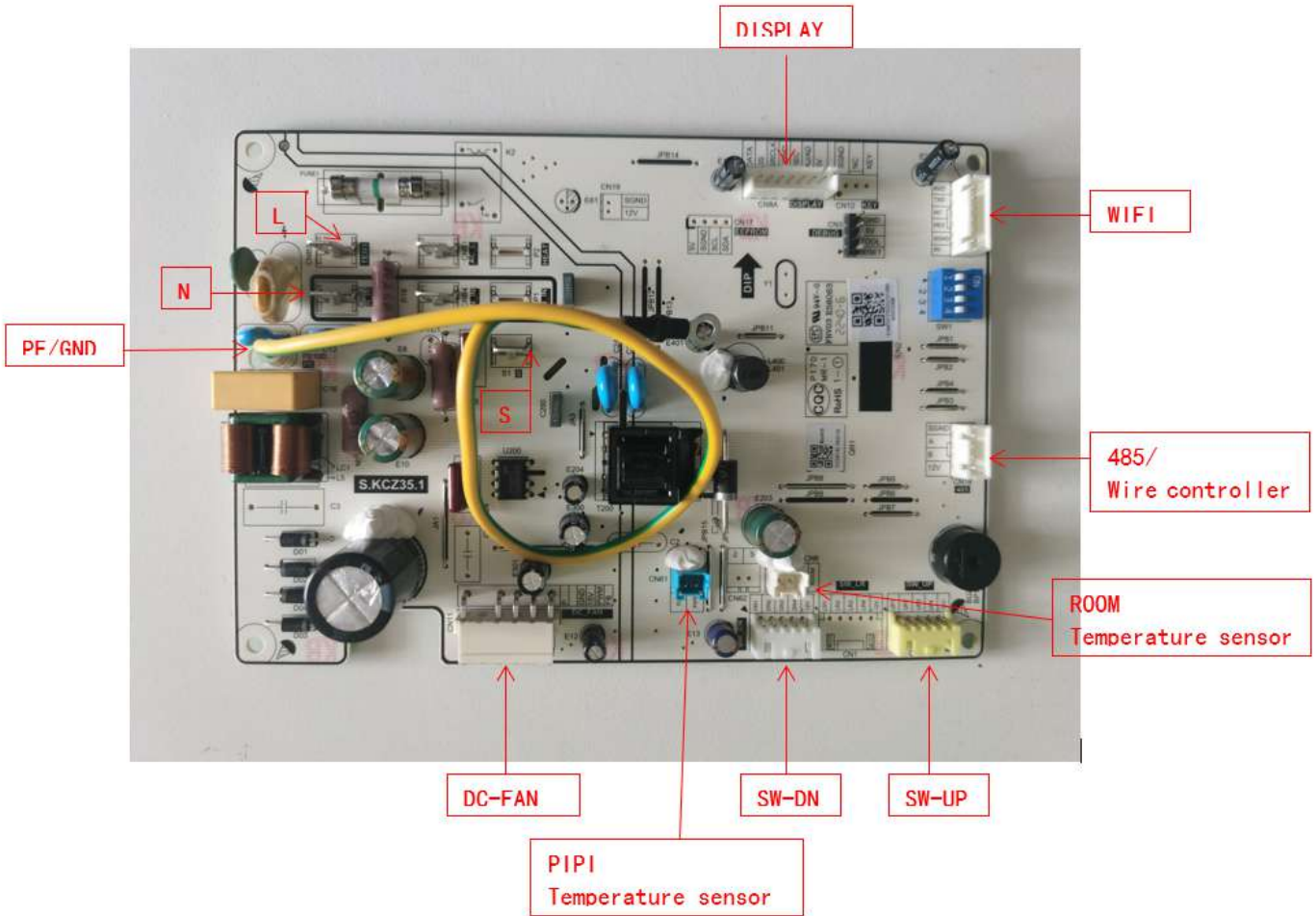

# Part11 Protection

## 1. High Temperature Protection

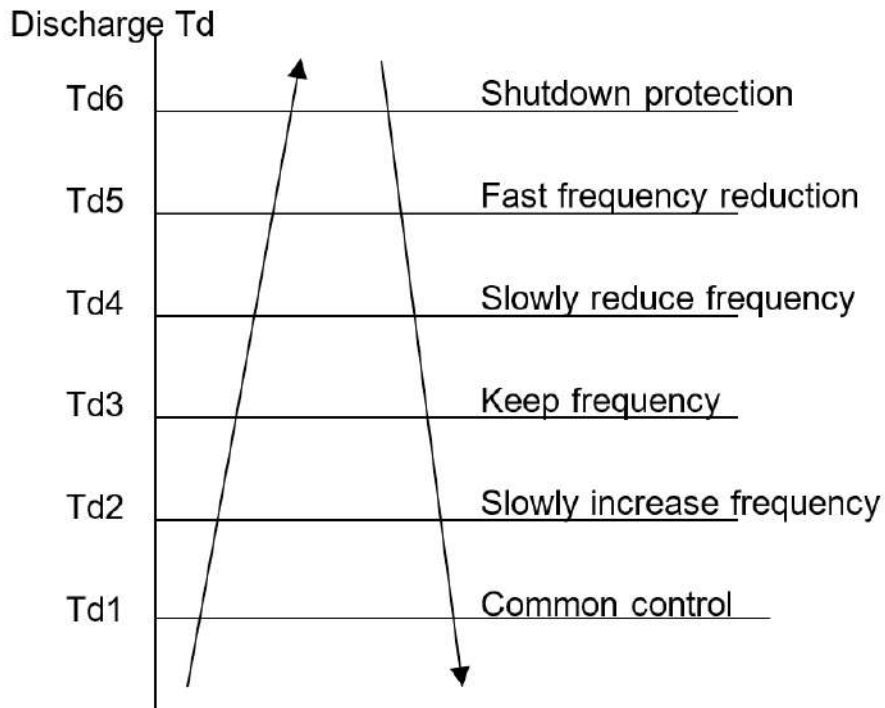

## 2. Over Current Protection

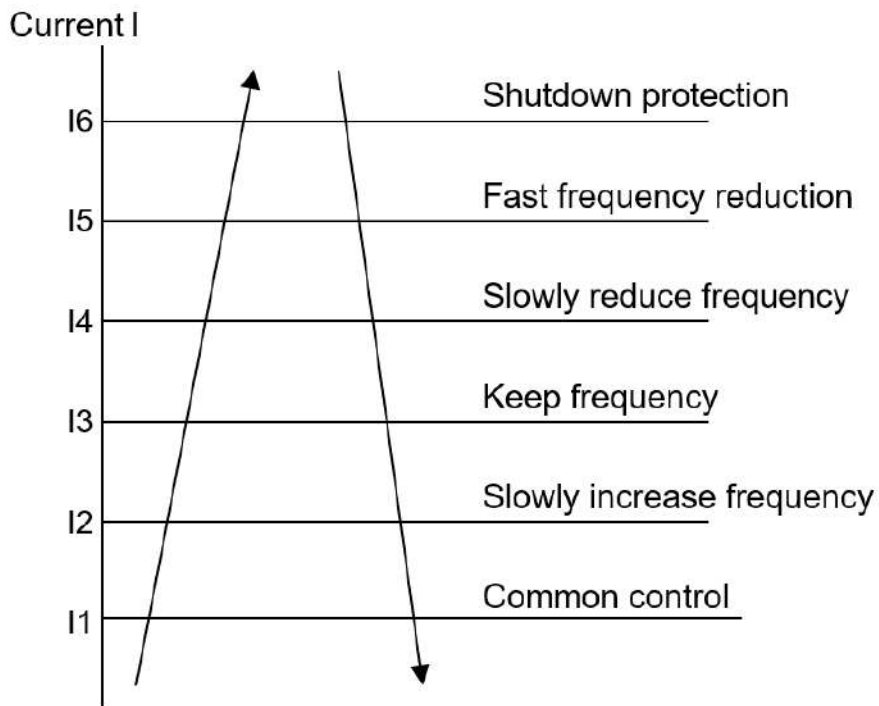

### 3. High Pressure Protection

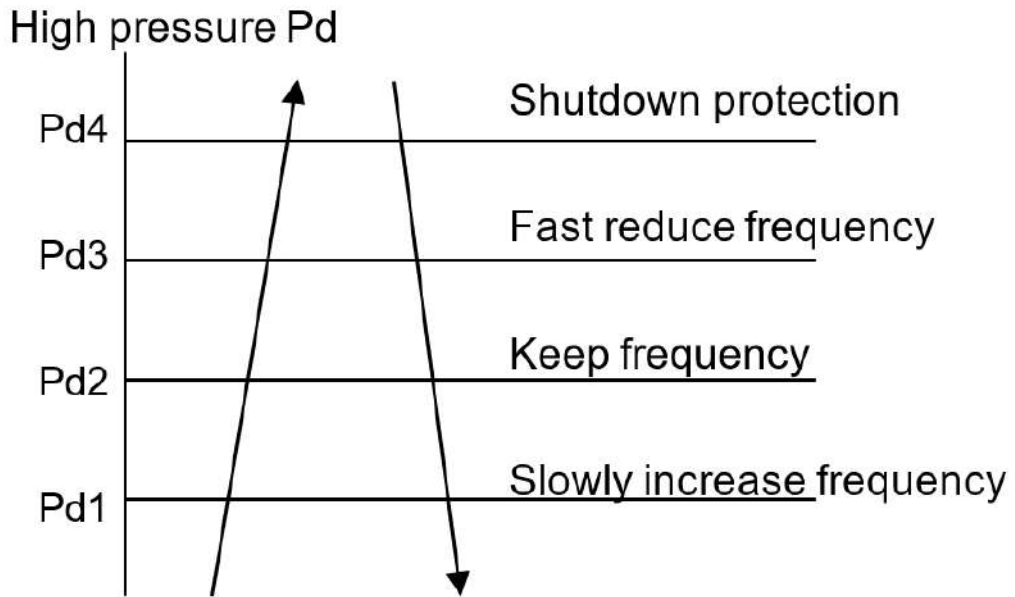

### 4. Low Pressure Protection

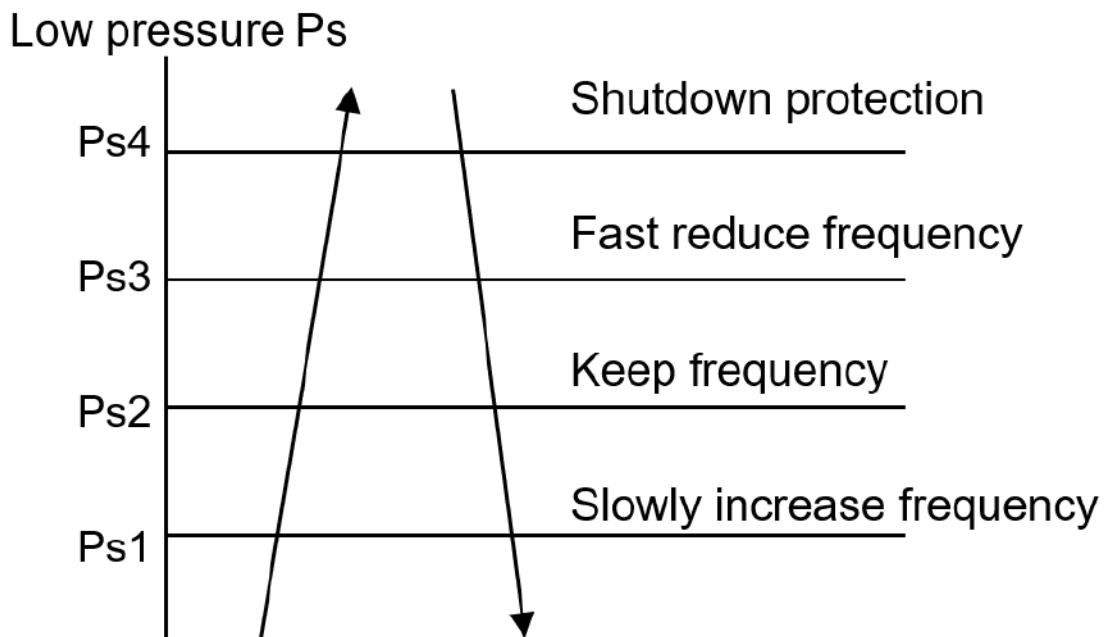

## Part12 Electric Characteristic

model	power supply		current		ODU fan motor input ( kW)
	Hz	voltage	MCA	MOP	
AL-H12/NDR3HB2(U)	50&60 Hz	220-240	/	9	35
AL-H18/NDR3HB2(U)		220-240	/	12	40
AL-H24/NDR3HB2(U)		220-240	/	16	65
AL-H30/NDR3HB2(U)		220-240	/	16	65
AL-H36/NDR3C2(U)		220-240	/	25	90
AL-H42/NDR3C2(U)		220-240	/	25	90
AL-H48/SDR3C2(U)		380-415	/	12	130
AL-H60/SDR3C2(U)		380-415	/	12	130

# Part13 Trouble Shooting

CA/ CF/ Duct /Co: Ceiling floor /Cassette/Duct/Console unit; WM: wall mounted unit

## 1. Failure code display

ERROR CODE	DESCRIPTION	Causes of possible failure
A1	Fault with the room temperature sensor on the Indoor unit	Damage of the room temperature sensor on the indoor unit
		Poor contact of the room temperature sensor on the indoor unit
		Damage of wiring of the room temperature sensor on the indoor unit
		Damage of the main PCB on the indoor unit
A2	Fault with the temperature sensor in the middle of indoor evaporator	Damage of the temperature sensor on the indoor unit
		Poor contact of the temperature sensor on the indoor unit
		Damage of wiring of the temperature sensor on the indoor unit
		Damage of the main PCB on the indoor unit
A3	Fault with the liquid pipe temperature sensor on the indoor unit	Damage of the liquid pipe temperature sensor on the indoor unit
		Poor contact of the liquid pipe temperature sensor on the indoor unit
		Damage of wiring of the liquid pipe temperature sensor on the indoor unit
		Damage of the main PCB on the indoor unit
A4	Fault with the gas pipe temperature sensor on the indoor unit	Damage of the gas pipe temperature sensor on the indoor unit
		Poor contact of the gas pipe temperature sensor on the indoor unit
		Damage of wiring of the gas pipe temperature sensor on the indoor unit
		Damage of the main PCB on the indoor unit
A5	Fault with the drainage	Float switch disconnected or poor wiring
		Error setting of model parameters
		Drain plug
		Damage of the pump
A6	Fault with the Fan motor of indoor unit	Low voltage
		Poor wiring
		Damage of the main PCB on the indoor unit
		Damage of the motor

ERROR CODE	DESCRIPTION	Causes of possible failure
A8	Indoor unit EEPROM module failure	Indoor unit PCB is broken EEPROM module is broken.
A9	Communication error between the outdoor unit and the indoor unit	Damage of the main PCB on the indoor unit Damage of the main PCB on the outdoor unit Poor wiring
AA	Communication error between the wired controller and main PCB of the indoor unit	Poor wiring Damage of the wired controller Damage of the main PCB on the indoor unit
H1	Fault with the high-pressure switch	System pipeline blockage Damage of the pressure switch
H4	Fault with the low-pressure switch	Lack of the refrigerant Stop valve unopened Damage of the pressure switch
C1	Fault with the Environmental temperature sensor on the outdoor unit	Damage of the Environmental temperature sensor on the outdoor unit Poor contact of the Environmental temperature sensor on the outdoor unit Damage of wiring of the Environmental temperature sensor on the outdoor unit Damage of the main PCB on the outdoor unit
C2	Fault with the defrosting temperature sensor on the outdoor unit	Damage of the defrosting temperature sensor on the outdoor unit Poor contact of the defrosting temperature sensor on the outdoor unit Damage of wiring of the defrosting temperature sensor on the outdoor unit Damage of the main PCB on the outdoor unit
C3	Fault with the discharge temperature sensor	Damage of the discharge temperature sensor on the outdoor unit Poor contact of the discharge temperature sensor on the outdoor unit Damage of wiring of the discharge temperature sensor on the outdoor unit Damage of the main PCB on the outdoor unit
C6	Fault with the suction temperature Sensor	Damage of the suction temperature sensor on the outdoor unit Poor contact of the suction temperature sensor on the outdoor unit Damage of wiring of the suction temperature sensor on the outdoor unit Damage of the main PCB on the outdoor unit

ERROR CODE	DESCRIPTION	Causes of possible failure
C8	Fault with the temperature sensor in the mid of outdoor condenser	Damage of the temperature sensor on the outdoor unit
		Poor contact of the temperature sensor on the outdoor unit
		Damage of wiring of the temperature sensor on the outdoor unit
		Damage of the main PCB on the outdoor unit
J2	Communication error between the outdoor unit and the indoor unit	Damage of the main PCB on the indoor unit
		Damage of the main PCB on the outdoor unit
		Poor wiring
J3	Communication error between the driver PCB and main PCB of the outdoor unit	Damage of the driver PCB on the outdoor unit
		Damage of the main PCB on the outdoor unit
		Poor wiring
J7	Fault with the outdoor unit EPROM	Chip damage
E1	Fault of four-way valve	Damage of four-way valve
		Damage to coil of four-way valve
E3	Protection high temperature discharge	Lack of the refrigerant
		Stop valve unopened
		Damage of the main PCB on the outdoor unit
E8	Fault with anti-high temperature protection of indoor unit in heating model	Outdoor condenser viscera
		Indoor evaporator viscera
FH	Protection lower temperature discharge	Temperature sensor shedding
		Damage of the main PCB on the outdoor unit
31	Fault with the inverter module protection	Fault with the inverter module protection
32	Compressor drive hardware protection	Damage of the EE chip of driver board
33	Module software protection	Supply voltage below level let the current excessive
		Supply voltage exceed limit
		Outdoor fan stops or low speed
34	Compressor start failure	Compressor power line not connected
35	Fault with the over-electric current protection	Excessive running current of the unit
		Voltage drops abruptly in operation
36	Fault with the over-voltage or low voltage protection	Excessive input voltage
		Lower input voltage
37	Fault with the modular temperature sensor on the outdoor unit	Sensor damage of compressor IPM module

ERROR CODE	DESCRIPTION	Causes of possible failure
38	Fault with the Compressor Power supply Phase efficiency protection	Compressor power line not connected
39	Protection of compressor driving module for excessive temperature	Poor contact between compressor IPM module and radiator
3H	Fault with the Fan motor of outdoor unit	Damage of motor
3C	Overcurrent protection of outdoor DC motor	High speed of DC motor
3J	Overvoltage protection of outdoor DC motor	Low voltage output
3E	Compressor drive PFC software protection	Excessive running current of the unit
		Voltage drops abruptly in operation
3F	Compressor drive PFC hardware protection	Damage of the PFC circuit components
		Reactor damage
41	IPM protection for driving board of outdoor DC fan	Damage of IPM components of DC fan
99	Communication error between the driver PCB and main PCB of the indoor unit	Abnormal power supply of fan driving board
		Poor contact of the communication line of fan drive board
		Damage of fan driving board
9A	Temperature protection of indoor DC fan module B L5	Damage of fan driving board
9H	Failure of indoor DC fan start-up	Damage of fan motor
		High speed of DC motor
9C	Overcurrent protection of indoor DC motor	Excessive running current of fan motor
9J	Overvoltage and undervoltage protection of indoor DC motor	Excessive input voltage
		Lower input voltage
9E	IPM protection for driving board of indoor DC fan	Sensor damage of Dc motor IPM module
9F	EE protection for driving board of indoor DC fan	Damage of EE chip of Driver board

## 2. Failure analysis

### 2.1 【AA】 Wired controller communication failure

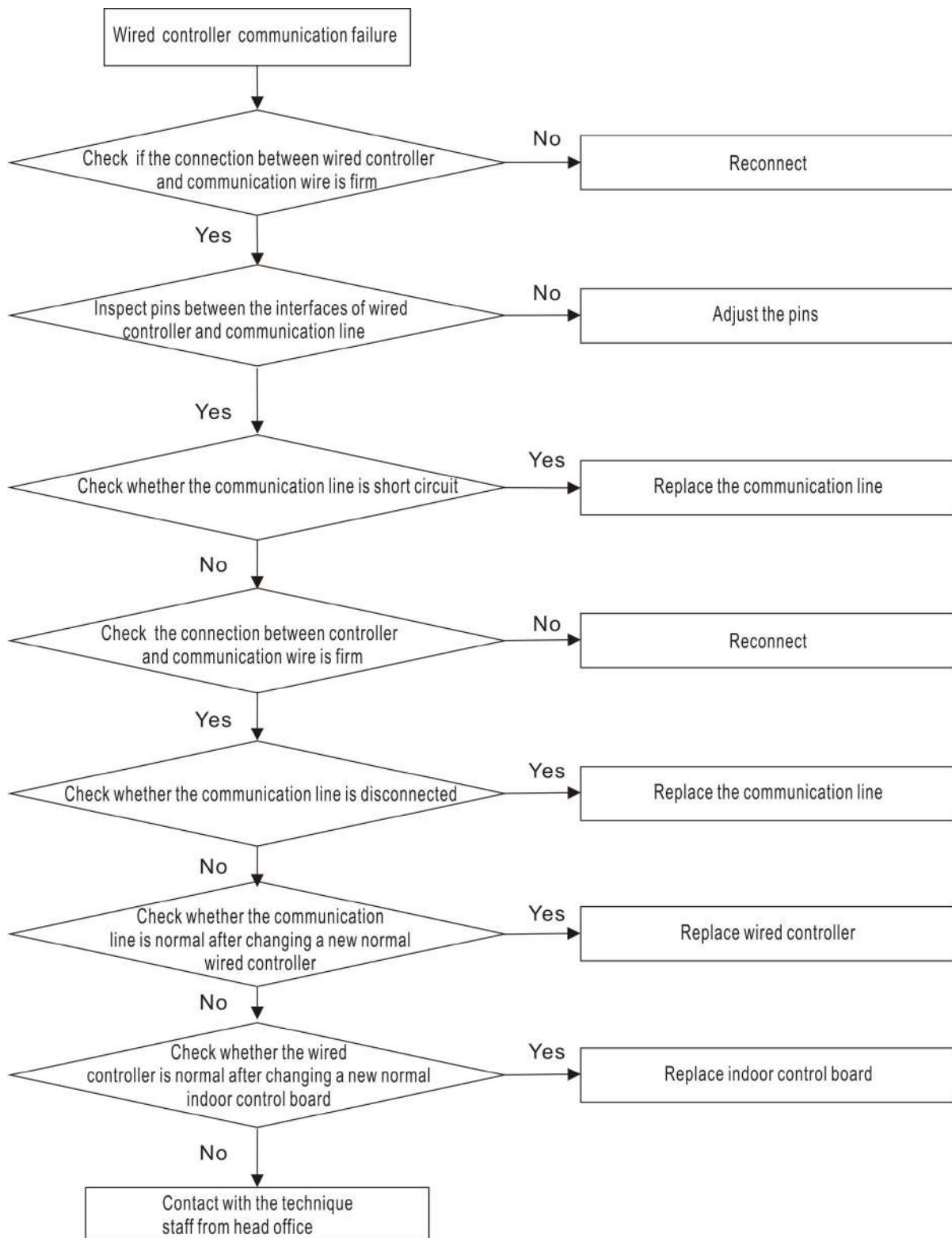

2.2 【A9】 Communication failure between indoor and outdoor unit

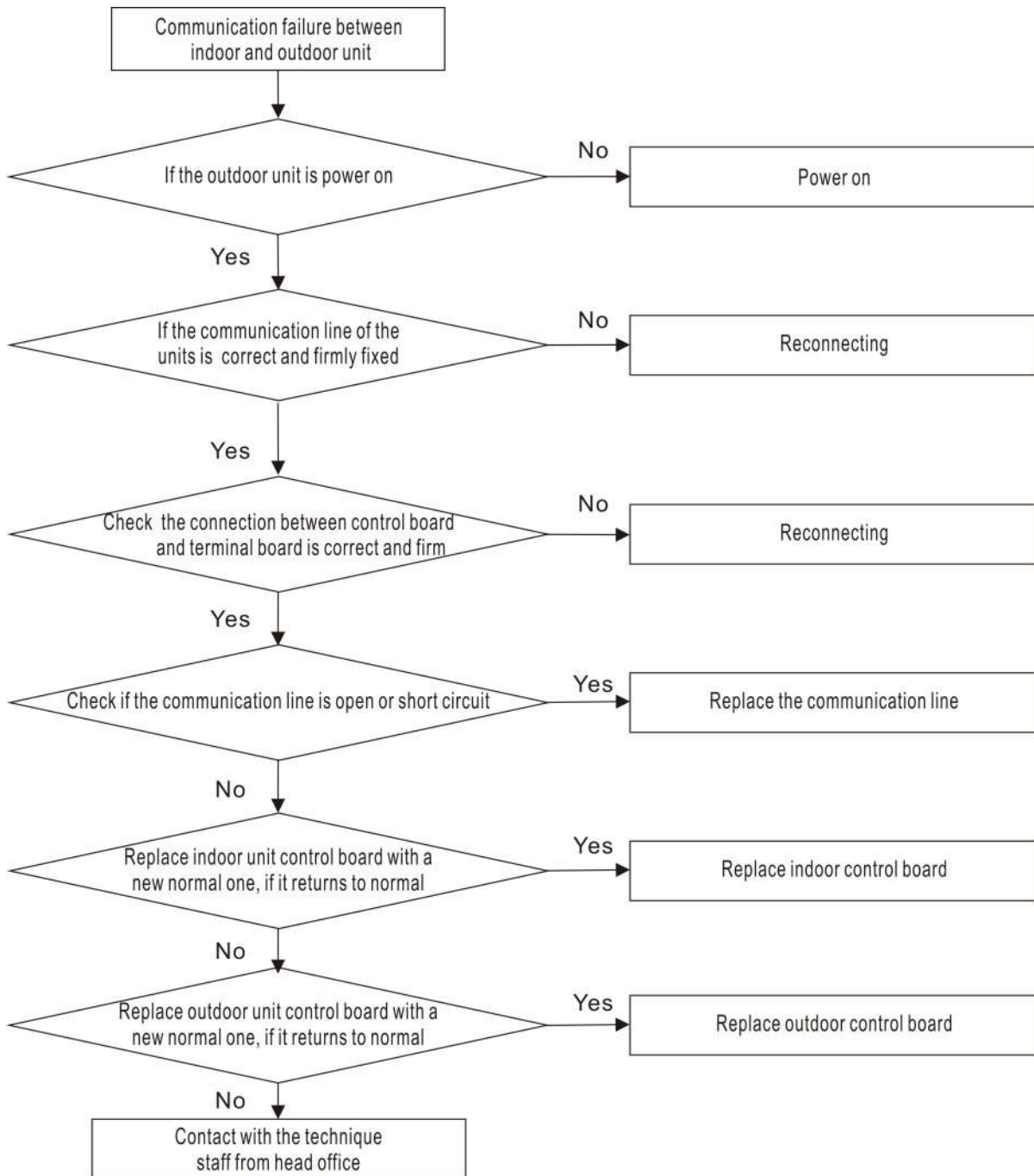

Outdoor protection (phase sequence)

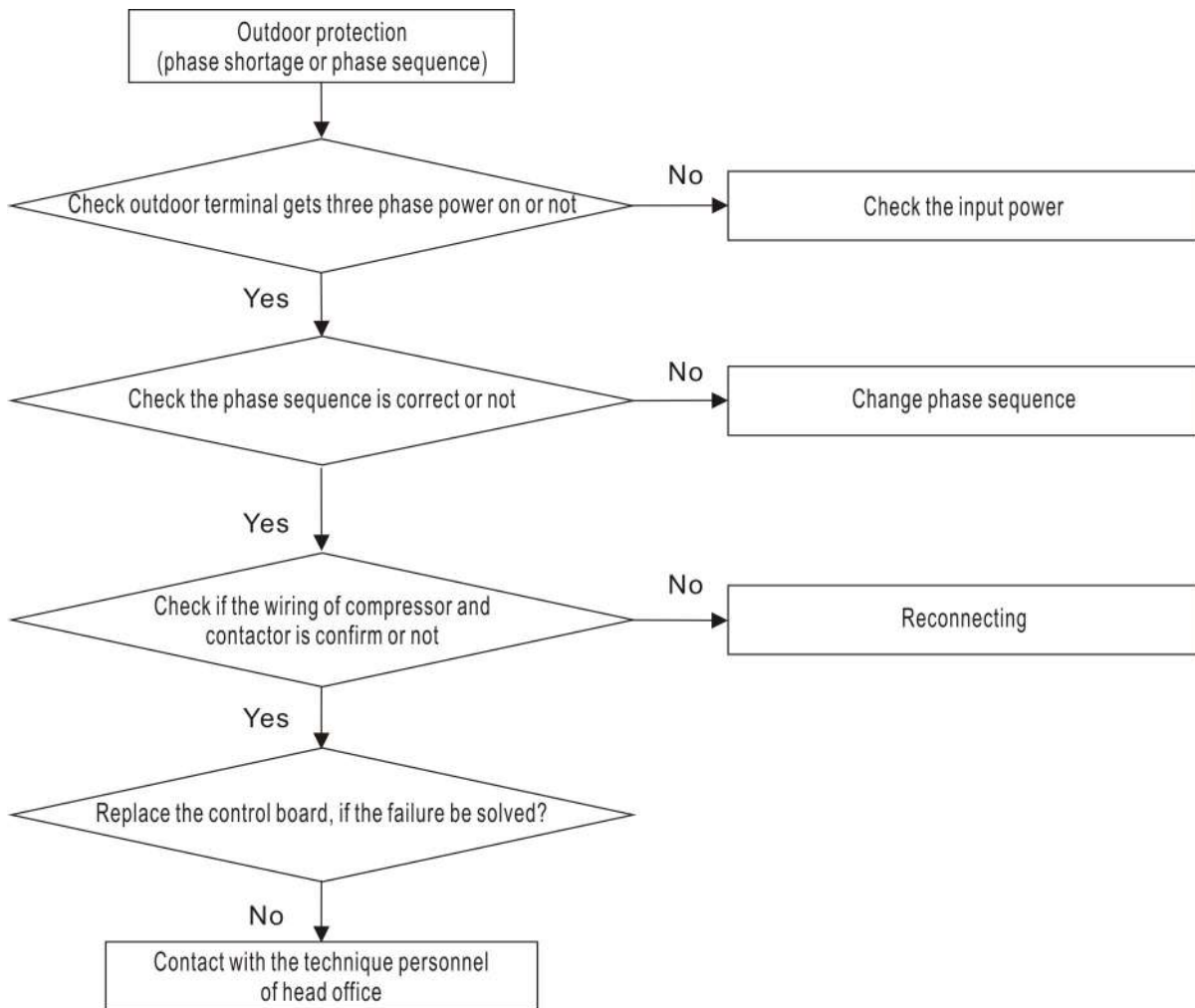

2.3 【H1】 high pressure protection

Cooling high pressure protection

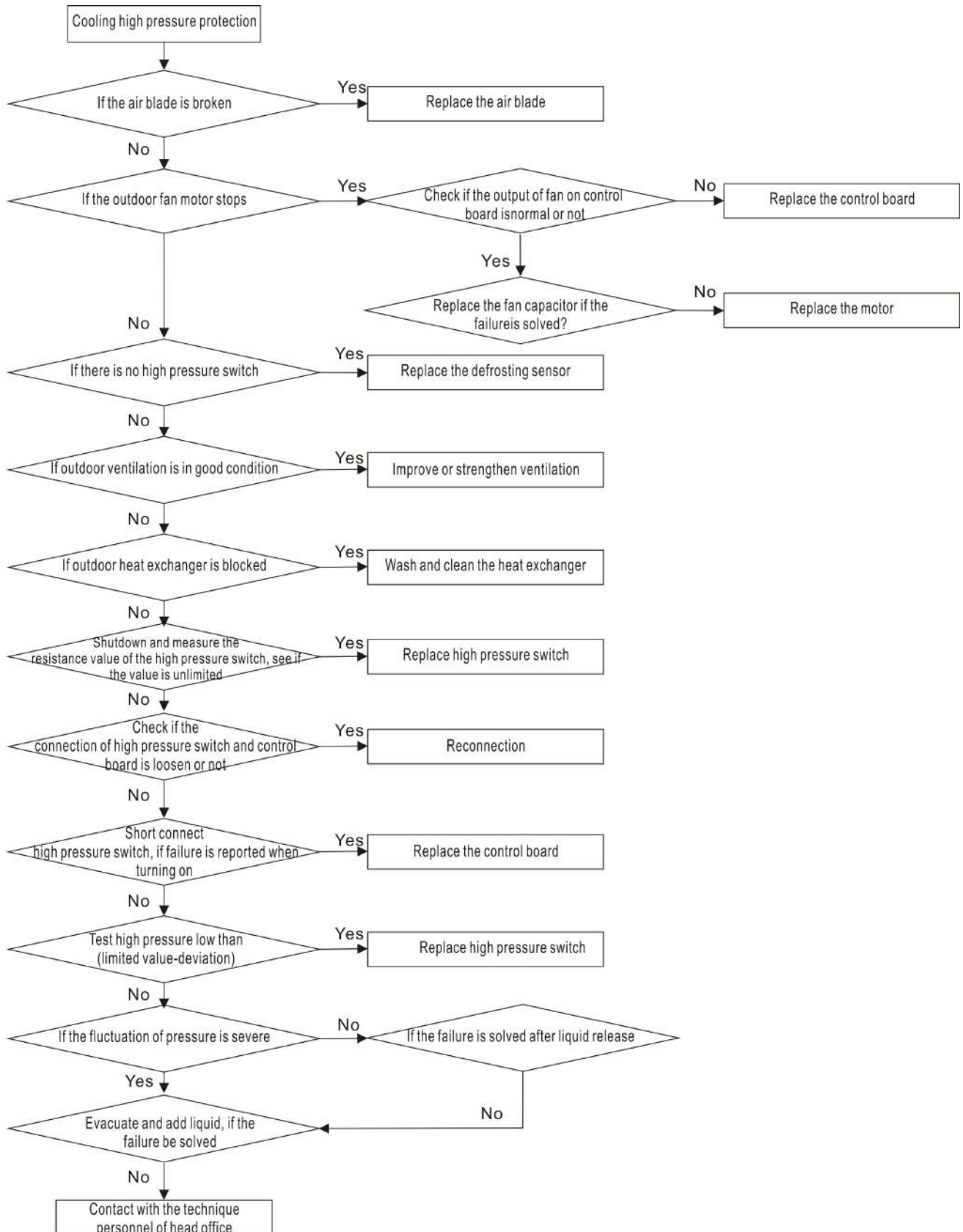

Heating high pressure protection

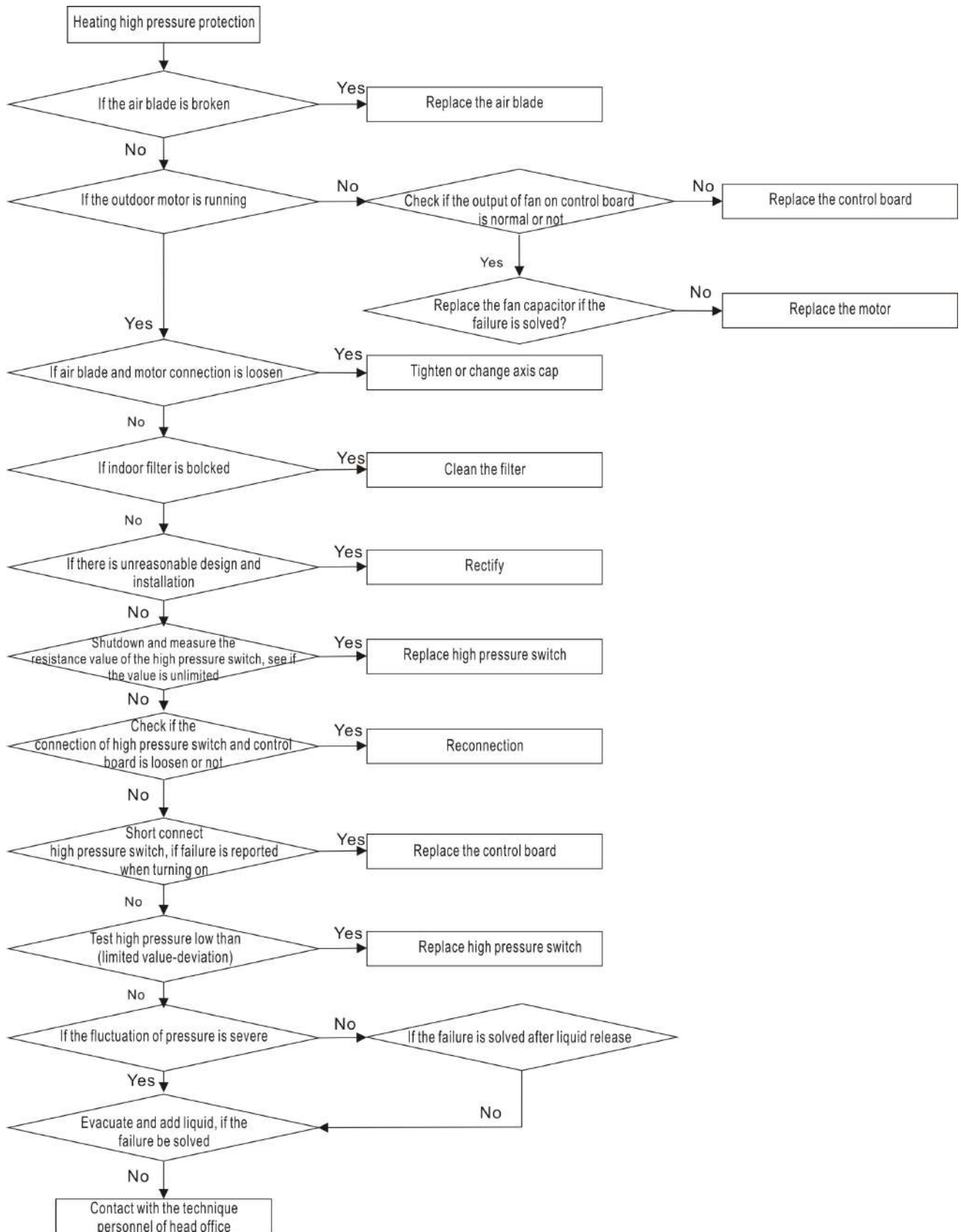

2.4 【H4】 low pressure protection

2.4.1 Cooling low pressure protection

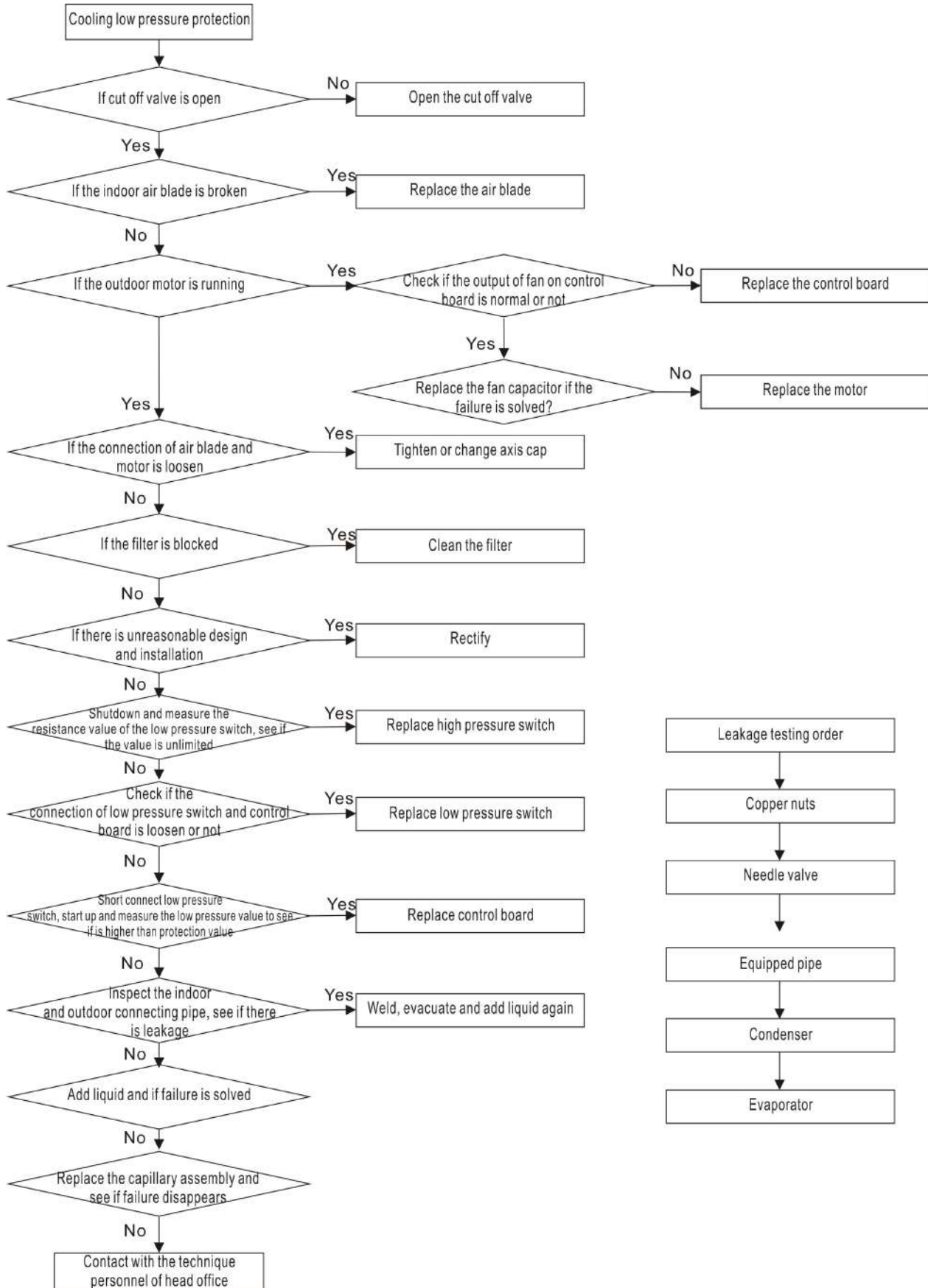

2.4.2 Heating low pressure protection

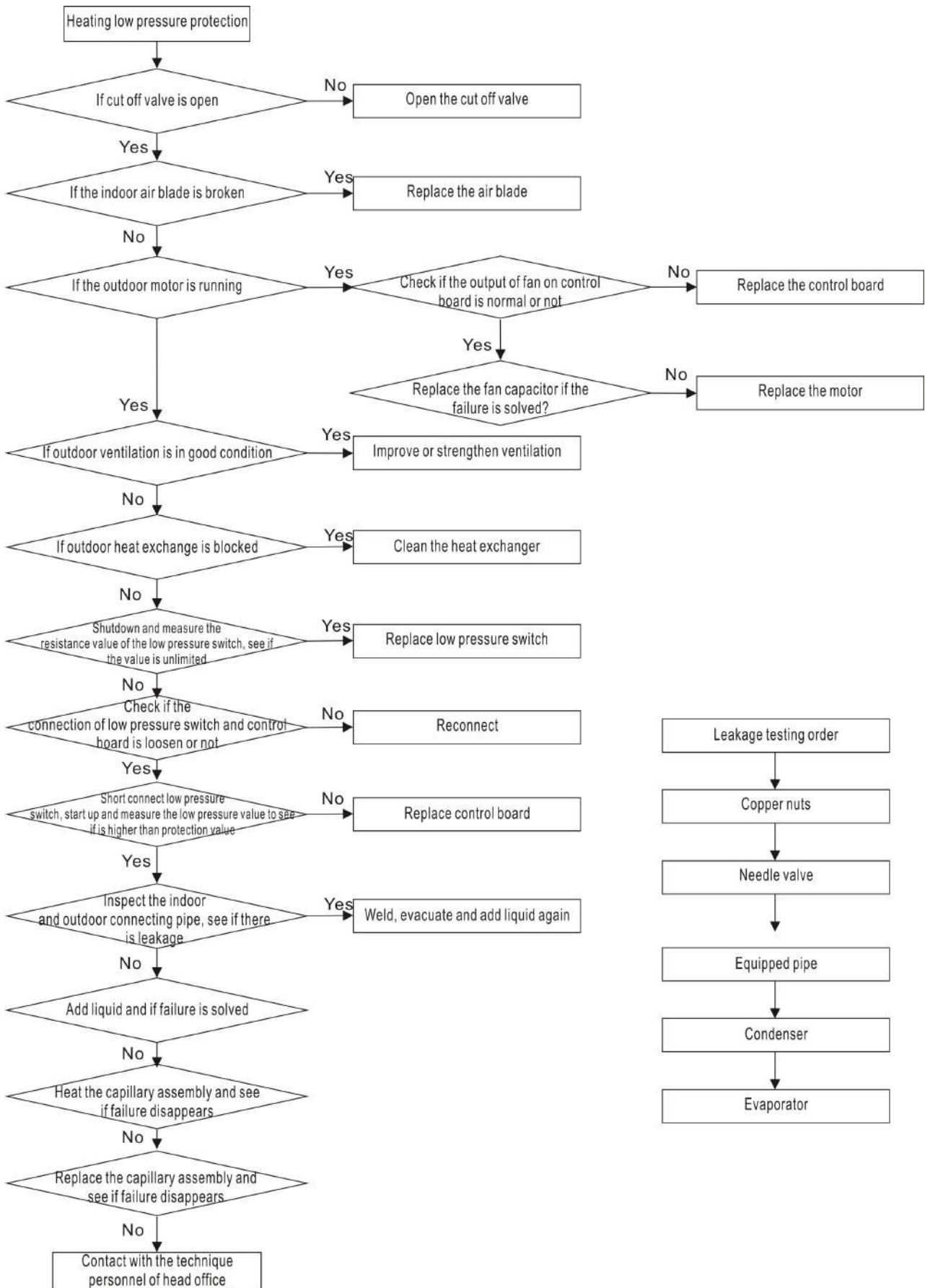

## 2.5 【E3】 High exhaust temperature protection

### Cooling exhaust temperature protection

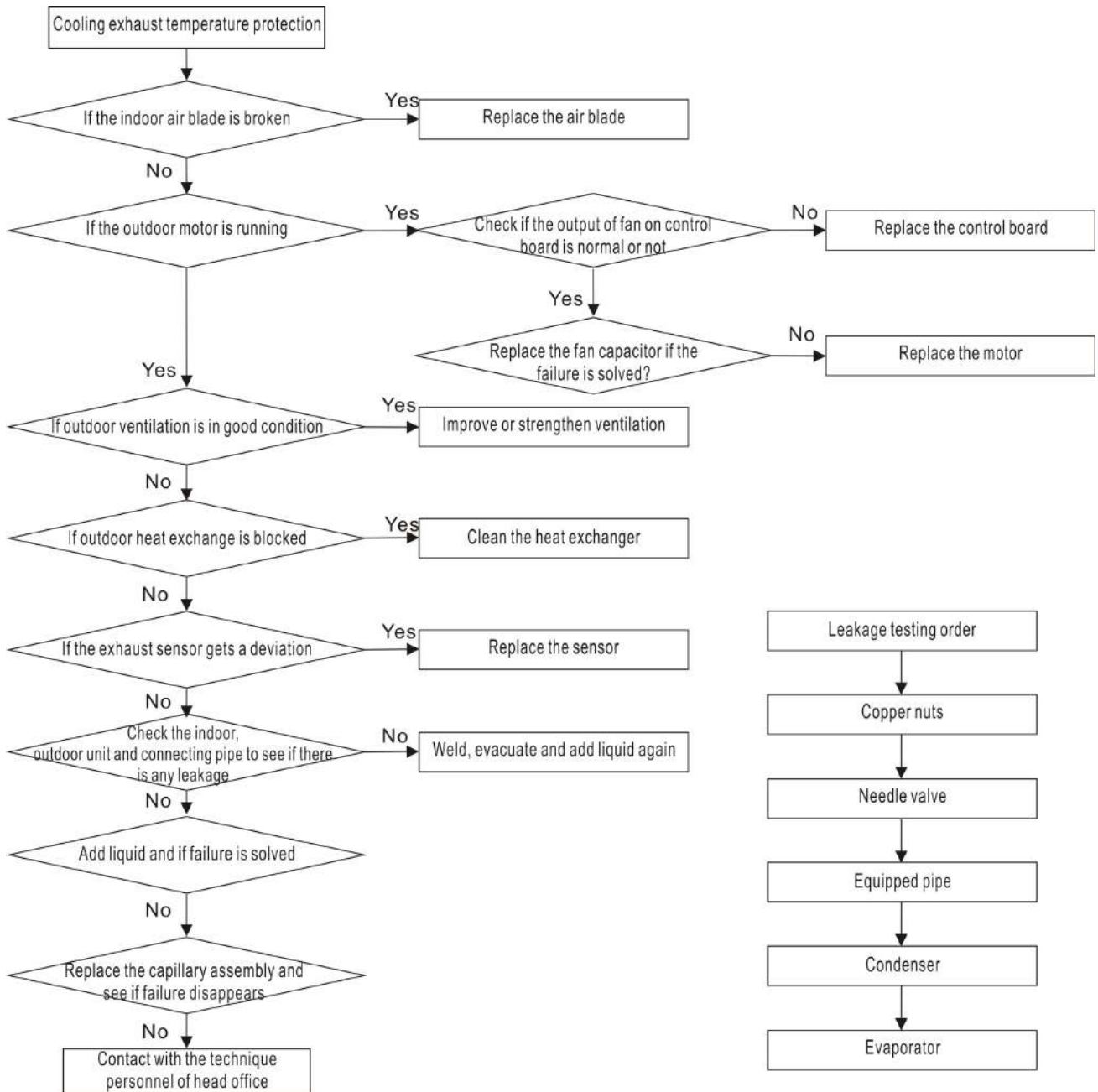

Heating exhaust temperature protection



2.6 【E1】 four way valve failure protection

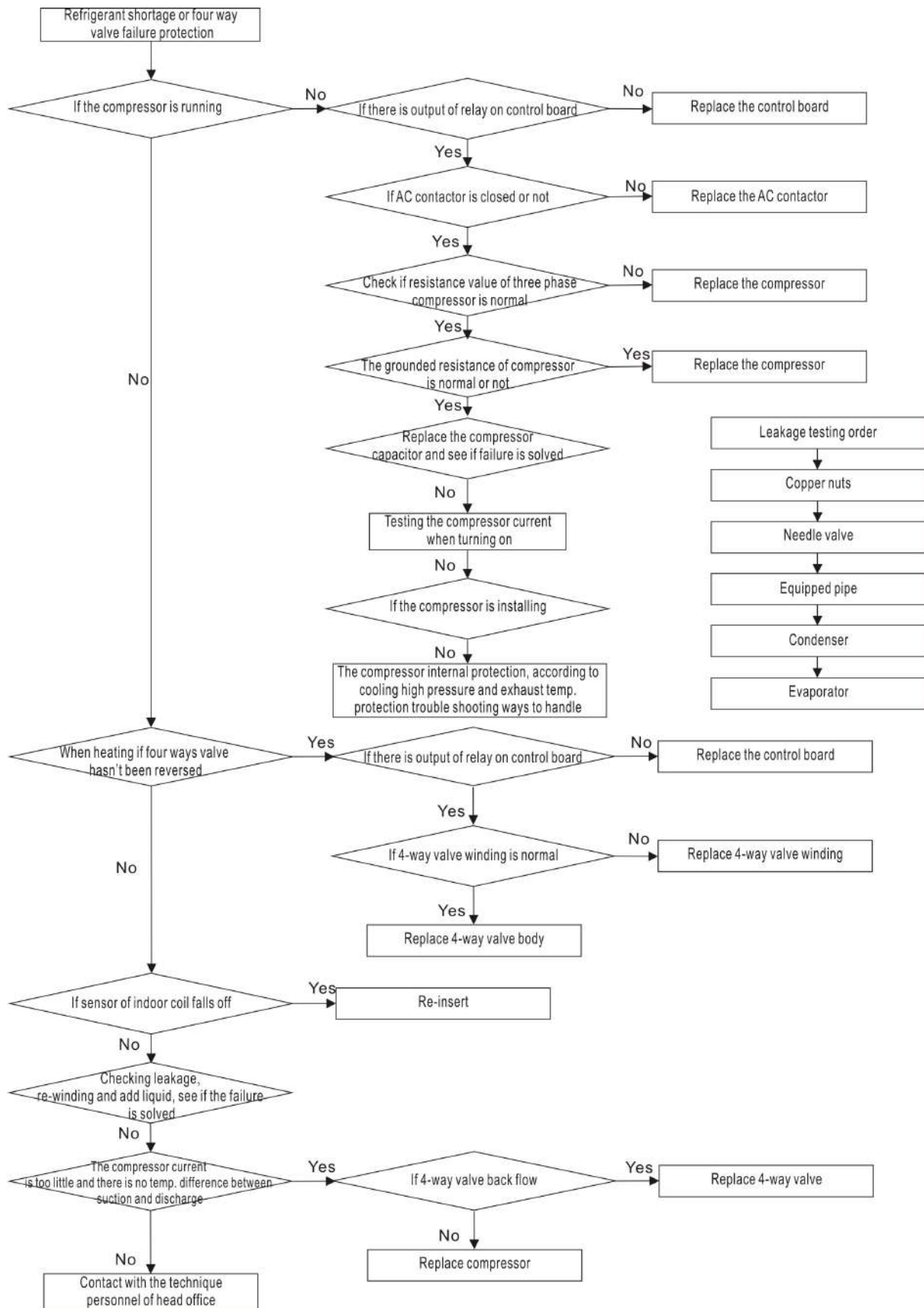

### 2.7 Sensor failure protection

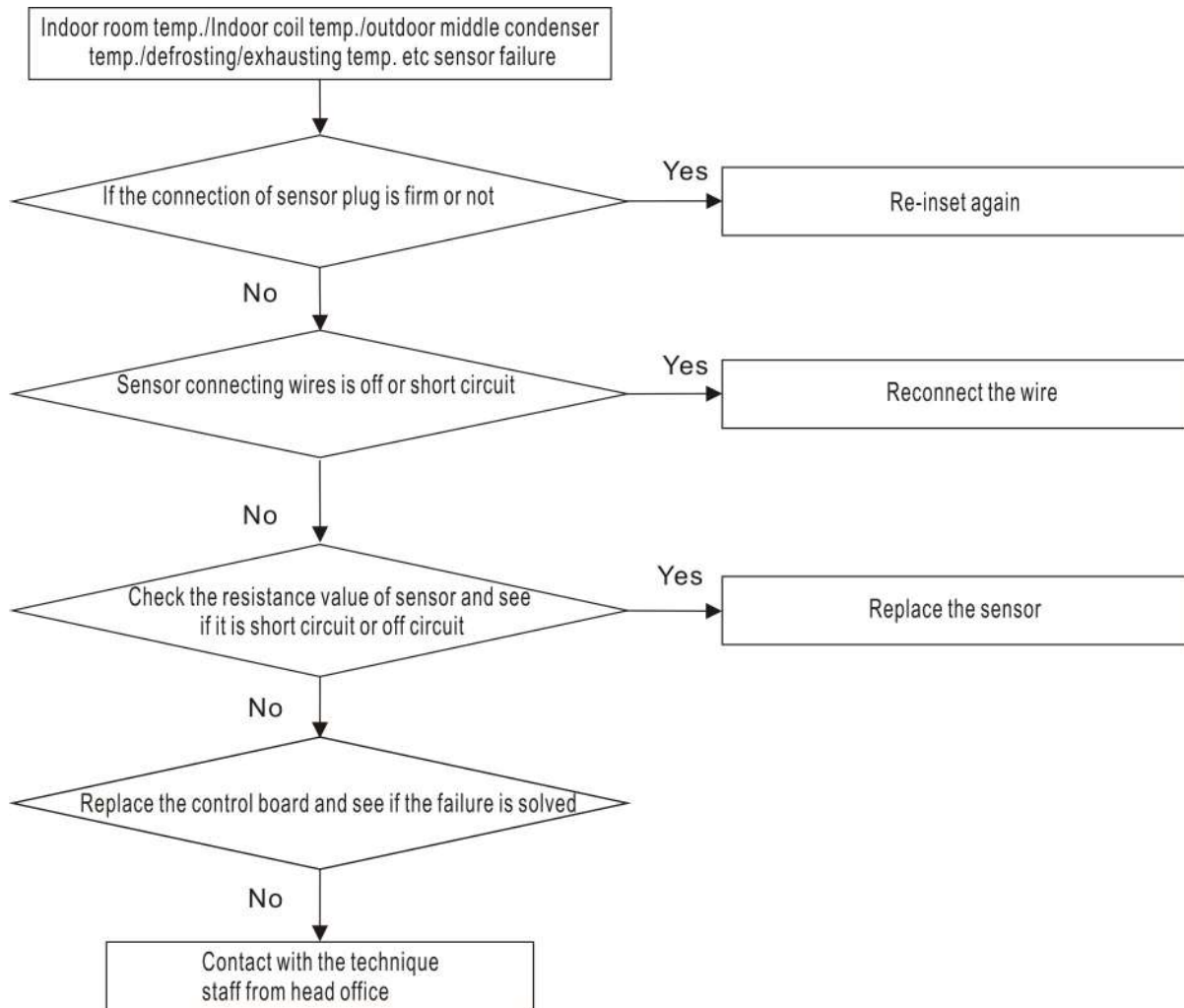

## Update Record

Version	Updater	Update Content
2020413 版	阳露	1. Delete some installation information. Refer to the R&D specifications 2. Delete the auspicious parameter, and EXCEL shall prevail
2020415 版	张标	1.358 Communication C5 crane disabled, changed to 458 Communication C5 crane, A → B 2. Operation range, (-10~52,15~24) → (-15~52, -15~24),
20200508 版	尹春梅	1. Update the appearance drawing and electrical schematic diagram of F new lift 2. Add 48K type F hanger explosion diagram and explosion list
20200828 版	尹春梅	1. Add the content related to F seat crane 36k 2. Complete the fault code
2020.10.27 版	刘卓	1. Add 42/60K related content for F seat crane 2. Smallpox E is changed to Smallpox Y 3. Distinguish between the old and the new
20210201	阳露	Updated the explosion drawing and list of F type hanger from 3D to 2D drawings
20210530	阳露	New Y type smallpox 18K
20220413	王鹏程	Against the latest spectrum, updates are as follows: 1. Delete eliminated products (Information of eliminated products, if you need to query, please find in the folder of Eliminated Products of pdm) 2. Increase noise parameters 3. Increase electrical characteristic parameters 4. Introduction to the protection function
20220525	王晓熙	1、 1. Add contents related to 12K, 18K, 24K and 30K external machines 2、 2. Add contents related to 12K, 18K and 24K types of Y smallpox 3、 3. Add contents related to 18K, 24K and 30K models of air ducts 4、 4. Add 18K and 24K F type hanger 5、 5. Spectrum diagram of internal machine noise in new products
20221028	Harry.Tong	1、 Add new indoor unit: Console
20221122	张亚雄	1、 Add new indoor unit: 18K duct
20230206	Harry.Tong	1:Delete ALCA-H12/NDR3HYA 、 ALCA-H18/NDR3HYA 、 ALCA-H24/NDR3HYB 、 ALMD-H18/NDR3HA 、 ALMD-H24/NDR3HA 、 ALMD-H36/NDR3HA 、 ALCF-H18/NDR3HF 、 ALCF-H24/NDR3HF 、 old ODU ( 800×315×545 、 900×350×700 、 970×395×805mm) 2. Add new indoor units: ALMD-H12/NDR3HM2A
20230309	Choy	1.Add 12, 18, 24, and 30k throttle elements is capillarie description 2.Add 48k,60k switch setting description
20230814	Choy	1.Add 48, 60k new production information
20230814	Steven	1.Add 36, 42K new production information
20240813	Steven	1. Fixed some errors.