

Domestic hot water  
tank  
Air Conditioning  
Technical Data  
CKHWS-BV3



CKHWS180BJV3  
CKHWS230BJV3



# TABLE OF CONTENTS

# CKHWS-BV3

---

1	Features	4
	CKHWS-BV3	4
2	Specifications	5
3	Dimensional drawings	6
4	Centre of gravity	7
5	Piping diagrams	8
6	Wiring diagrams	9
	Wiring Diagrams - Single Phase	9
7	External connection diagrams	13
8	Installation	14
	Installation Method	14

# 1 Features

## 1 - 1 CKHWS-BV3

› Up to 4 indoor units and 1 domestic hot water tank can be connected to 1 multi outdoor unit

› Domestic hot water efficiencies up to A+

› Floor-standing domestic hot water tank available in 180l and 230l

1



## 2 Specifications

### 2 - 1 Specifications

Technical specifications				CKHWS180BV3	CKHWS230BV3	
Dimensions	Unit	Height	Tank	mm	1,655	1,855
		Width		mm		595
		Depth		mm		634
	Packed unit	Height		mm	1,820	2,020
		Width		mm		720
		Depth		mm		740
Weight	Unit	Empty		kg	106	115
	Packed unit	Empty		kg	120	130
Packing	Material			Wood / Carton / Metal / PE wrapping foil		
	Weight			kg	13.3	13.6
Tank	Water volume			l	180	230
	Material			Stainless steel (EN 1.4521)		
	Maximum water temperature			°C	65	
	Maximum water pressure			bar	10	
Insulation	Heat loss		kWh/24h	1.2 (1)	1.4 (1)	
	Material			Polyurethane foam		
Energy efficiency class				B		
Standing	S		W	50	58	
Storage volume	V		l	180	220	
Backup heater	Quantity				1,0	
	Capacity			kW	1,5	
Piping connections	Refrigerant inlet heat exchanger diameter			inch	1/4"	
	Refrigerant outlet heat exchanger diameter			inch	5/8"	
	Cold water in			inch	G 3/4" (female)	
	Hot water out			inch	G 3/4" (female)	
	Recirculation connection			inch	G 3/4" (female)	
Sound power level	Domestic hot water heating				42,0 (2)	
Safety devices	Item			01	Thermal cut out	
General	Supplier/	Name and address		Daikin Europe N.V. - Zandvoordestraat 300, 8400 Oostende, Belgium		
	Manufacturer details	Name or trademark		Daikin Europe N.V.		

Electrical specifications				CKHWS180BV3	CKHWS230BV3
Power supply	Phase				1~
	Frequency			Hz	50
	Voltage			V	230
Electric heater	Power	Voltage		V	230
	supply	Name			3V
		Phase			1~
	Current	Maximum running current		A	6.5
		Zmax	List	Ω	see note 3
		Minimum Ssc value			Equipment complying with EN/IEC 61000-3-12
Recommended fuses			A	10 (3)	

(1)Based on dT of 45 K |

(2)DHW flow |

(3)2-pole 10A, curve 230V |

(4)Above mentioned power supply of the hydrobox is for the backup heater only. The switch box and the pump of the hydrobox are supplied via the outdoor unit.

# 3 Dimensional drawings

## 3 - 1 Dimensional Drawings

3

### CKHWS-BV3

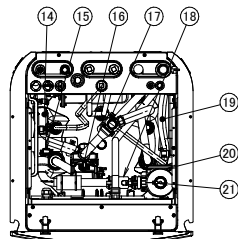
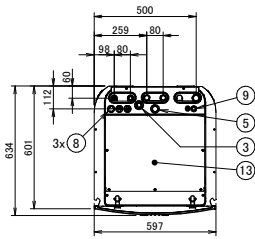

SERVICE PANEL OFF

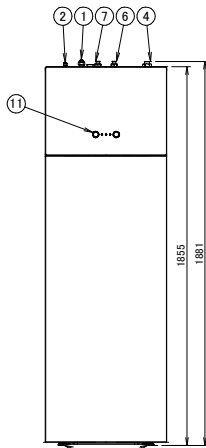

CKHWS230\*

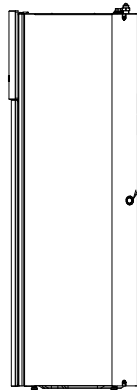

CKHWS180\*

The typical field installation has to be done according to the applicable legislation. For examples, refer to the installer reference guide.

- ① Gas pipe connection · 5/8" (15,9 mm) · flare
- ② Liquid pipe connection · 1/4" (6,35 mm) · flare
- ③ Chimney
- ④ Water in connection · 1" BSP
- ⑤ Recirculation connection · G3/4" (female)
- ⑥ Domestic hot water: cold water in · 3/4" BSP-F
- ⑦ Domestic hot water: hot water out · 3/4" BSP-F
- ⑧ High voltage wiring intake · Ø24 mm
- ⑨ Low voltage wiring intake · Ø15 mm
- ⑩ Levelling feet
- ⑪ User interface
- ⑫ Drain outlet
- ⑬ Hydro module service panel
- ⑭ Water filter
- ⑮ Space heating water pressure sensor
- ⑯ Pump
- ⑰ Pressure relief valve
- ⑱ Flow sensor
- ⑲ Expansion vessel
- ⑳ Backup heater
- ㉑ Air purge

Screws used in this unit:

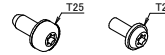

3D154573A

# 4 Centre of gravity

## 4 - 1 Centre of Gravity

CKHWS-BV3  
CKHWSU-BV3

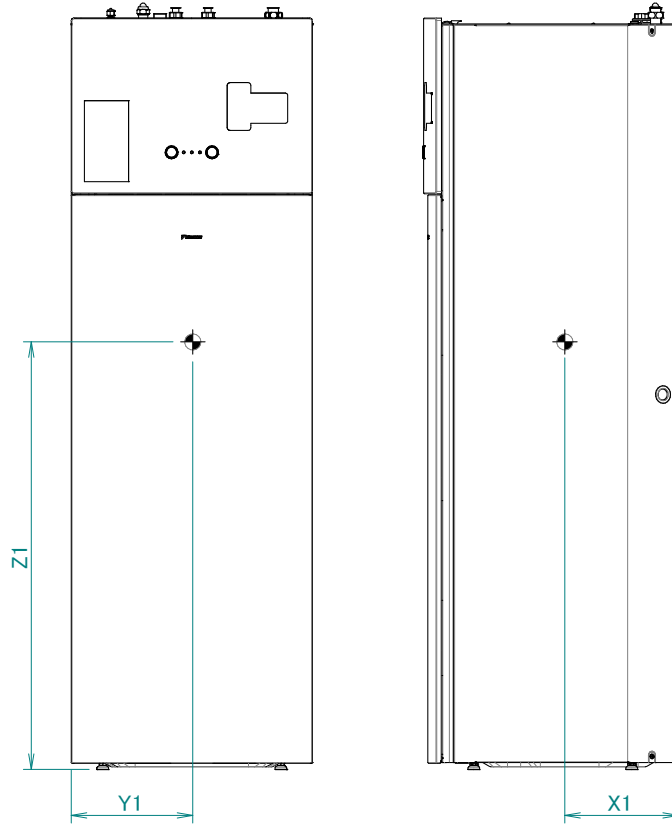

3D156335

# 5 Piping diagrams

## 5 - 1 Piping Diagrams

5

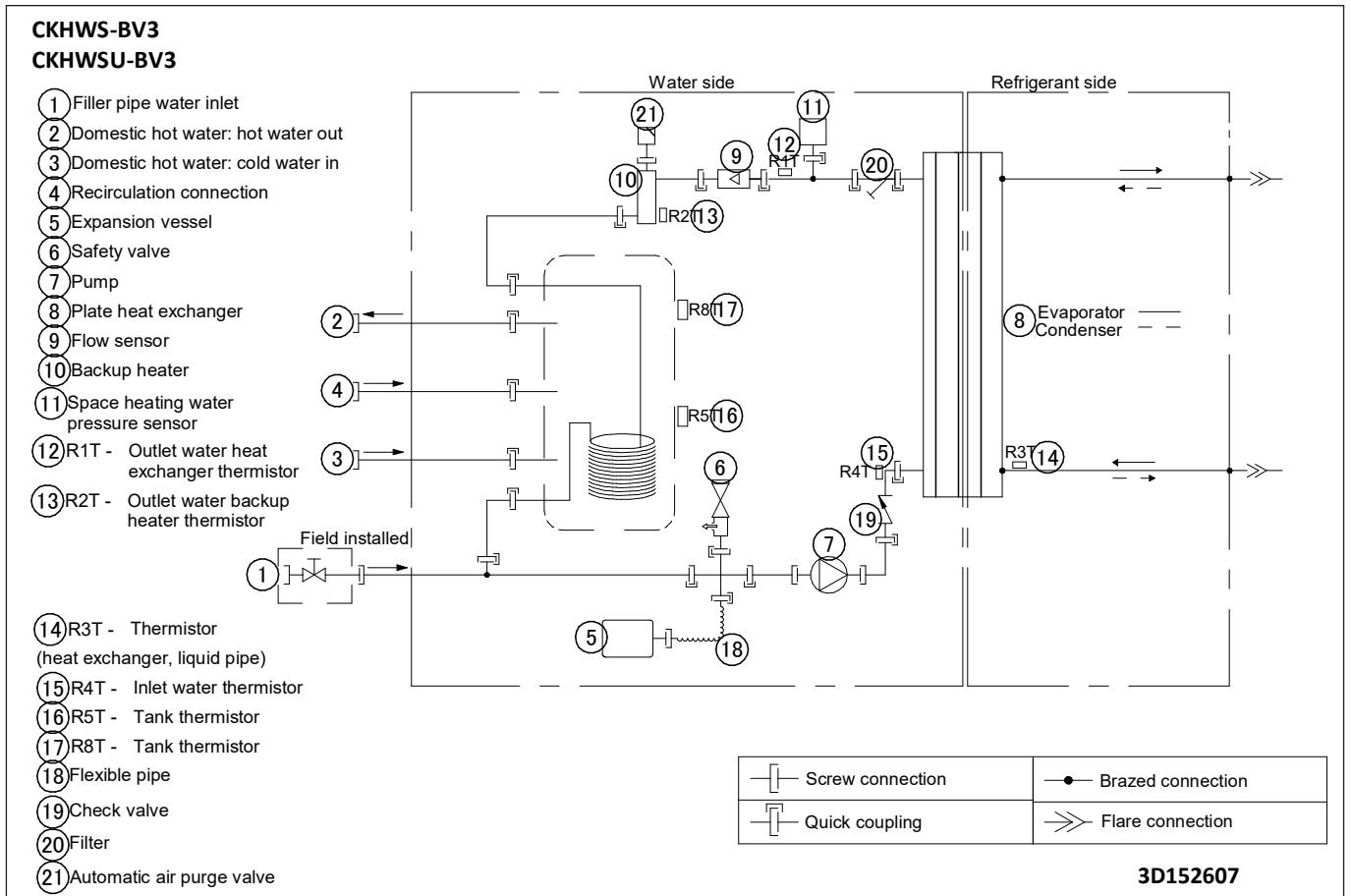

# 6 Wiring diagrams

## 6 - 1 Wiring Diagrams - Single Phase

CKHWS-BV3  
CKHWSU-BV3

**NOTES to go through before starting the unit**

- X1M : Main terminal
  - X2M : Field wiring terminal for AC
  - X5M : Field wiring terminal for DC
  - X6M : BUH Power supply terminal
  - : Earth wiring
  - - - - - : Field supply
- ① : Several wiring possibilities
  - [ ] : Option
  - [ ] : Wiring depending on model
  - [ ] : Not mounted in switch box
  - [ ] : PCB

**NOTES**

1. Connection point of the power supply for the BUH/BSH should be foreseen outside the unit.

Backup heater power supply

- 3V (1N~, 230V, 1,5kW)

User installed options:

- Remote user interface
- WLAN adapter module
- WLAN cartridge

**POSITION IN SWITCH BOX**

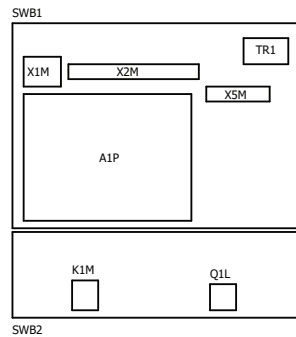

**LEGEND**

Part n°	Description
A1P	main PCB
A9P	status indicator
A11P	MMI main PCB
A14P	* user interface PCB
A20P	* WLAN module
B2L	pulse type flow sensor
B1PW	water pressure sensor
E1H	backup heater element (1,5 kW)
E*P (A9P)	indication LED
F1B	# overcurrent fuse backup heater
F2B	# overcurrent fuse main
F1T	thermal fuse backup heater
FU1 (A1P)	fuse T 5 A 250 V for PCB
K1M	contactor backup heater
K*R (A1P)	relay on PCB
M1P	main supply pump
M2P	# domestic hot water pump
P1M	MMI display
Q1L	thermal protector backup heater
Q*DI	# earth leakage circuit breaker
R1T	outlet water heat exchanger thermistor
R1T (A14P)	* ambient sensor user interface
R2T	outlet backup heater thermistor
R3T	refrigerant liquid side thermistor
R4T	inlet water thermistor
R5T, R8T	domestic hot water thermistor
SW1~2 (A11P)	turn buttons
SW3~5 (A11P)	push button
TR1	power supply transformer
X6M	# BUH power supply terminal strip
J*, X*, X*A, X*H*, X*Y	connector
X*M	terminal strip

\* : optional # : field supply

4D151941A

CKHWS-BV3  
CKHWSU-BV3

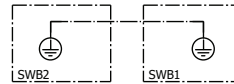
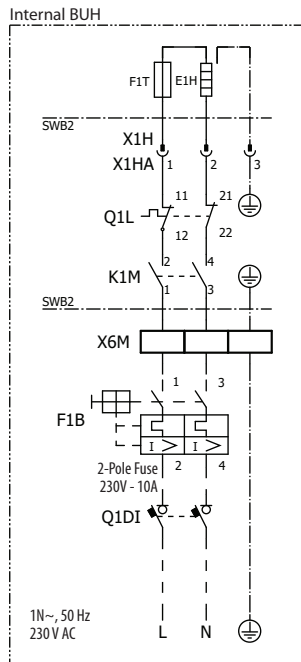

4D151941A

# 6 Wiring diagrams

## 6 - 1 Wiring Diagrams - Single Phase

6

CKHWS-BV3  
CKHWSU-BV3

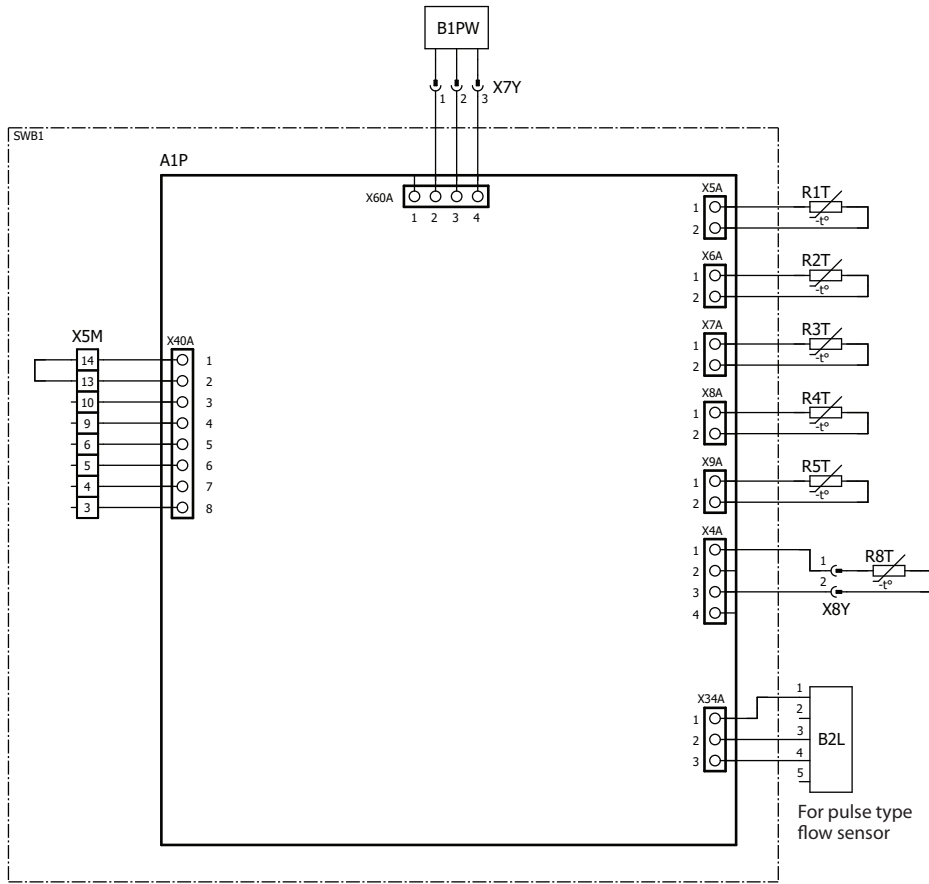

4D151941A

CKHWS-BV3  
CKHWSU-BV3

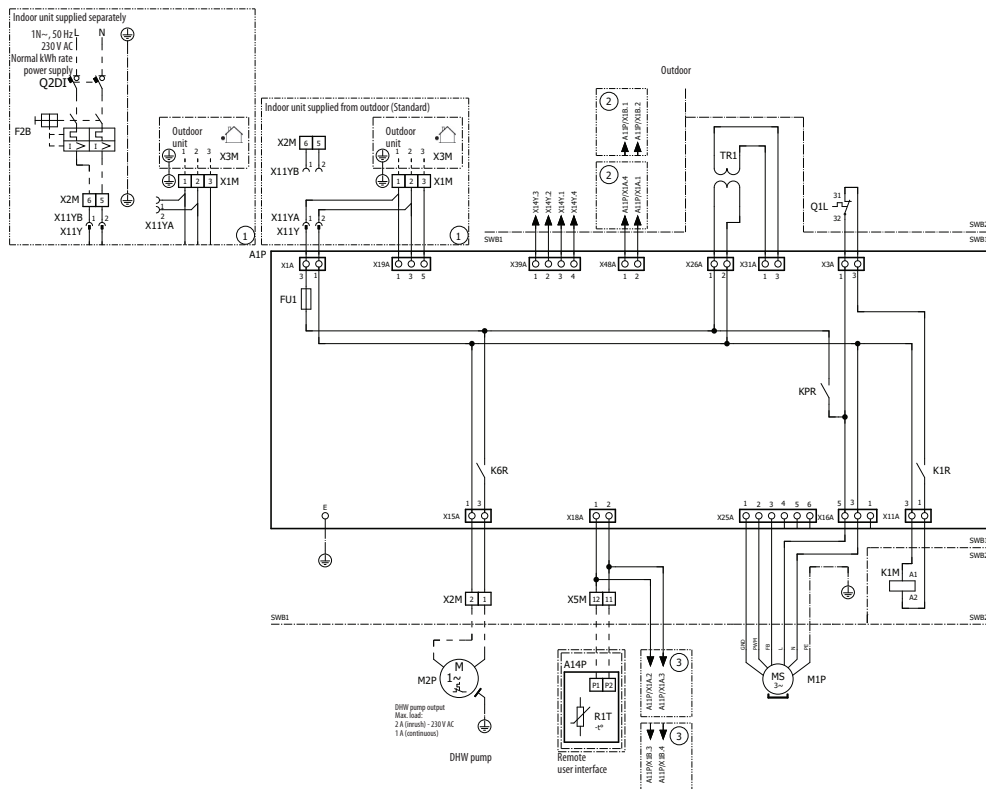

4D151941A



# 6 Wiring diagrams

## 6 - 1 Wiring Diagrams - Single Phase

6

CKHWS-BV3  
CKHWSU-BV3

**NOTES to go through before starting the unit**

- X1M : Main terminal
  - X2M : Field wiring terminal for AC
  - X5M : Field wiring terminal for DC
  - X6M : BUH Power supply terminal
  - : Earth wiring
  - : Field supply
- ① : Several wiring possibilities
- [ ] : Option
- [ ] : Wiring depending on model
- [ ] : Not mounted in switch box
- [ ] : PCB

**NOTES**

1. Connection point of the power supply for the BUH/BSH should be foreseen outside the unit.

Backup heater power supply

- 3V (1N~, 230V, 1,5kW)

User installed options:

- Remote user interface
- WLAN adapter module
- WLAN cartridge

**POSITION IN SWITCH BOX**

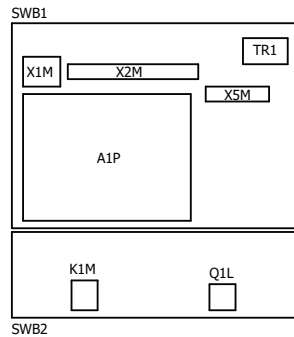

**LEGEND**

Part n°	Description
A1P	main PCB
A11P	MMI main PCB
A14P	* user interface PCB
A20P	* WLAN module
F1B	# overcurrent fuse backup heater
F2B	# overcurrent fuse main
FU1 (A1P)	fuse T 5 A 250 V for PCB
K1M	contactor backup heater
M2P	# domestic hot water pump
Q1L	thermal protector backup heater
Q*DI	# earth leakage circuit breaker
R1T (A14P)	* ambient sensor user interface
TR1	power supply transformer
X6M	# BUH power supply terminal strip
J*, X*, X*A, X*H*, X*Y	connector
X*M	terminal strip

\* : optional

# : field supply

4D154844A

# 7 External connection diagrams

## 7 - 1 External Connection Diagrams

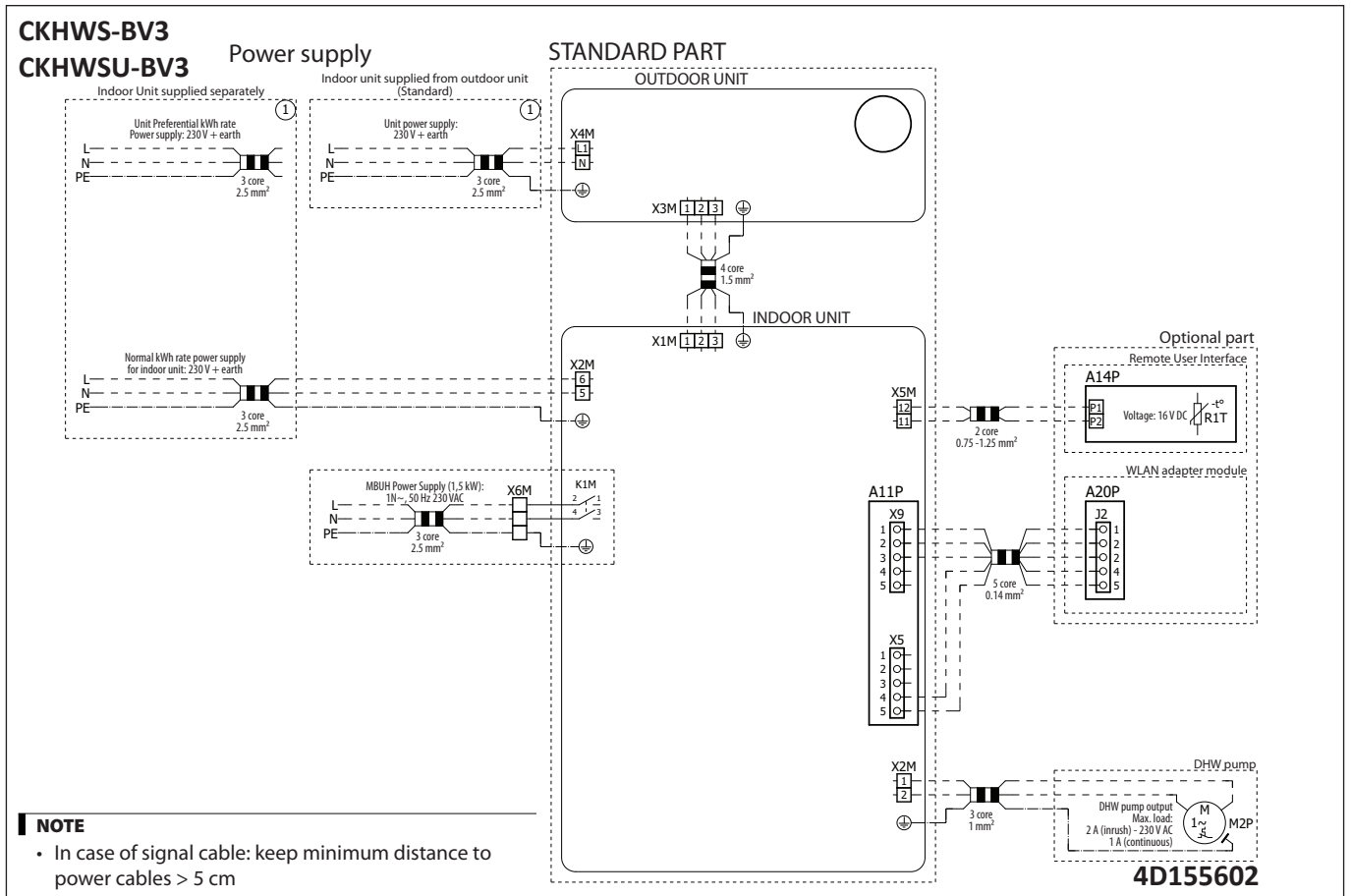

# 8 Installation

## 8 - 1 Installation Method

8

CKHWS-BV3

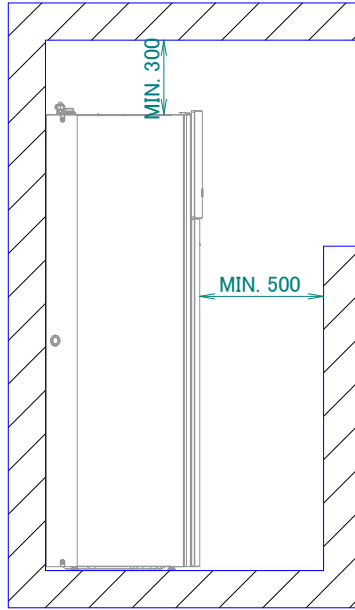
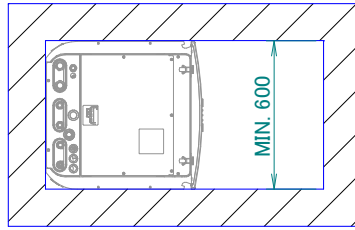

3D136826C



EEDEN25A

05/2025



The present leaflet is drawn up by way of information only and does not constitute an offer binding upon Daikin Europe N.V. Daikin Europe N.V. has compiled the content of this leaflet to the best of its knowledge. No express or implied warranty is given for the completeness, accuracy, reliability or fitness for particular purpose of its content and the products and services presented therein. Specifications are subject to change without prior notice. Daikin Europe N.V. explicitly rejects any liability for any direct or indirect damage, in the broadest sense, arising from or related to the use and/or interpretation of this leaflet. All content is copyrighted by Daikin Europe N.V.